

PEAC Fistful of Silver Appaloosa

& All Breed Open Horse Show

July 19th, 20th & 21st, 2024

Spokane Interstate Fairgrounds & Expo Center

N. 404 Havana Spokane, WA

Show Secretary

Dennis Weitman
24201 E. Josph Ave
Otis Orchards, WA
509-995-9867
peacoffice2@gmail.com



2024 Judges

Judge #1: ApHC
Christy Wood,
Three Oaks, CA

Judge 2: WSH/NEZ
Sherri Williams,
Yakima, WA.

Show Committee:

Jessicca Weitman, Sharon West,
Dennis & Michelle Weitman,
Rachael Schwartz, Verna Blackhurst,
Dan Caron & Caleb Heggemeier

WSH Show Steward:

Dawn Spencer,
Brinnon, WA

Show Manager:

Michelle Weitman

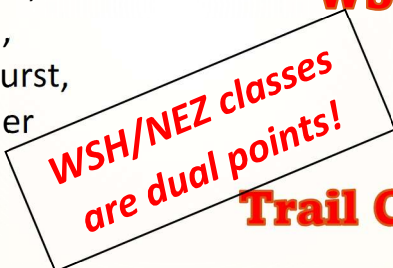

Trail Course & Equipment:

Michelle Weitman &
Sharon West

Announcer:

Daniel Schwartz

Show Photographer

Kelsey McCarty
KCM Equine Photography

High Points Point Keeper

Evelien Deelen
Verna Blackhurst

2024 APPROVALS



WSH
NEZ
ApHC



PEAC Fistful of Silver Appaloosa & All Breed Open Horse Show

Sponsored by Palouse Empire Appaloosa Club and is operated in accordance with the current rules of WASHINGTON STATE HORSEMEN Horse Show Division, of which body it is a " B " System Show. Every person who participates in the show is responsible for knowledge of and is subject to the Association Rules. Members receive a hard copy of The Canter, 3 times per year. Copies are available on the website www.WashingtonStateHorsemen.org.

Members are entitled to participate in the Annual High Score Award competition, if the horse is recorded and participation fees are paid for the current year.

NO POINTS WILL BE COUNTED TOWARD THE ANNUAL HIGH SCORE AWARDS before membership dues are paid, horses have been recorded with WSH, and all fees paid.

THE STEWARD OF THIS SHOW WILL HAVE FORMS FOR RECORDING AND PARTICIPATION.

Watch for more information regarding Convention on the Website www.WashingtonStateHorsemen.org

Nov. 8th-10th , 2024 Clover Island Inn, Kennewick, WA

To: WASHINGTON STATE HORSEMEN Horse Show Division

310 Rd 13 SW Royal City, WA 99357 509-760-6462

wshhsd@gmail.com

Please send me information on how I may participate in the Annual High Score Awards competition. PLEASE PRINT

Name _____

Address _____ City _____

State _____ Zip _____ E-Mail _____



Northeast Zone High Score Awards

This show is recognized by the Northeast Zone of WSH. To sign up for Northeast Zone High Score Awards contact Jole Chick, Chair 8810 S Spotted Road, Cheney, WA 99004-9164 509-954-3913.

To request form, email chickfamily1999@gmail.com. The Show office of the show also has forms to sign up for this awards program. It is easy and fun!



Friday July 19th, 2024- start 8am

Trail

Ranch/Reining

Saturday July 20th, 2024- 8am

Halter

Showmanship

Driving

Heritage

English

Gaming

Sunday July 21st, 2024, 8am start

Western

ApHC Class Entry Fees

ApHC Open \$ 24 per class

ApHC Youth \$ 18 per class

ApHC Non-Pro Classes \$22 per class

ApHC classes are not recognized by WSH "B" system points

WSH/NEZ & Other Class Fees

WSH/NEZ Classes \$20 per class

All Other Non-Sanctioned Classes \$20 per class

* denotes WSH approved classes

+ denotes NEZ approved classes

ENTRIES: must be plainly printed or typed and signed by Owner or Authorized Agent, the Rider/Driver/Handler, and any Coach or Trainer. Parent or Guardian signature is required if the Rider/Driver/Handler is a Junior Exhibitor. Numbers will not be released until all required parties have signed the Entry Form. Please circle only those classes you are submitting payment for. Riders/Drivers/Handlers sharing the same Horse must each be entered in the show on a separate entry form. Please include photocopies of your: 1) WSH Membership Card, 2) Current ABRA, AMHA, APHA, ApHC, AQHA, PtHA, NRHA, USE, WSH Amateur or Non-Pro Card if entering Amateur designated classes, and 3) Horse's registration papers if entering Breed classes. Please pay only one Stall and/or Tack room, Dry Camp or RV-Hook-Up per Entry Form; please do not split fees or pay another exhibitor's fees on your entry.

OPEN CHECKS: will be accepted for entries and it is the responsibility of the exhibitor to close their open checks. Should exhibitor fail to close out checks, they give PEAC permission to complete the amount of fees due to the club and hold PEAC harmless of any and all liability in doing the same.

EVERY CLASS OFFERED HEREIN WHICH IS COVERED BY THE RULES AND SPECIFICATIONS OF THE CURRENT WSH/NEZ RULEBOOK WILL BE CONDUCTED AND JUDGED IN ACCORDANCE THEREWITH. ALL OTHERS, WHERE APPLICABLE, WILL BE CONDUCTED AND JUDGED IN ACCORDANCE WITH THE CURRENT ApHC RULE BOOK

Jackpots 90% Payout!

Trail Horse \$50.00

Reining Jackpot \$50.00

Ranch Rail Jackpot \$50.00

Most Colorful Open \$50.00

Showmanship Jackpot \$50.00

English pleasure Jackpot \$50.00

Western Pleasure Jackpot \$50.00

Stalls, Camping and Other Fees

Post Entry One time Fee \$10 (except ApHC and WSH Youth Classes)

One Day Stall \$55 per stall

Two day stalls \$85 per stall

Weekend Stalls \$115 per stall (Thursday 3pm thru Sunday 6pm)

Tack Stall \$50 per stall (weekend)

One Day Tack Stall \$25 per stall (24hrs or less)

Haul In Fee \$15 (non-stalled) per Horse

All camping With or Without hook up \$45 per night.

Office Fee \$5 onetime fee

WSH nonmember fee \$3 per exhibitor/ judge (\$6 for dual judge).

Closing Date for PRE-ENTRIES received before July 12th, 2024.

There are no post entry fees on ApHC youth & WSH youth classes

CAMPING VEHICLES MUST SHOW CARD/PASS OR MOVE VEHICLE, DISCONNECT OR PAY AGAIN



Trail Horse Jackpot



Test your skills in the Trail Horse, English or Western Jackpot class
Judged to the WSH Trail Horse Open rules
No ApHC or WSH/NEZ points



Reining Horse Jackpot

Test your skills in the Reining Horse Jackpot Class
Judged to the WSH Open Reining rules NRHA Pattern #1
No ApHC or WSH/NEZ points



Most Colorful Jackpot

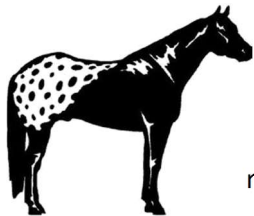

All breed halter class open to horses or ponies of color,
i.e. Appaloosa, Pinto, Paint, Buckskin, Palomino, Cremellos, etc.
registration papers are not required. Judged 60% color and 40% conformation.
No ApHC or WSH/NEZ points



English Pleasure Horse Jackpot

Test your skills in the English Pleasure Horse Jackpot Class
Judged to the WSH Open English Pleasure Sr. Horse rules
No ApHC or WSH/NEZ points



Western Pleasure Horse Jackpot



Test your skills in the Western Pleasure Horse Jackpot Class
Judged to the WSH Open Western Pleasure Sr. Horse rules
No ApHC or WSH/NEZ points

Showmanship Jackpot

Test your skills in the Showmanship Jackpot Class
Judged to the WSH Showmanship in hand Open rules
No ApHC or WSH/NEZ points



All Jackpots Pay out 90% of entry!

Each class will pay out 90% of it's class entry fee as the purse!
Class entries of 1-3 = 100% of purse to 1st
Class entries 4-7 = 1st =60%, 2nd =40%
Class entries of 8 or more = 1st =50%, 2nd =30%, 3rd=20%



PEAC FISTFULL OF SILVER HIGH POINT

PEAC Fistful of Silver Open/Appaloosa Horse Show is offering the following HIGH POINT AWARDS: (followed by a list of classes to count for each award, any changes to these will be posted in the show office)

**Points counted on a one horse & rider combination, except Miniature and Driving Horse/Pony.
Change of riders/handlers is not allowed (no combined points).
Some classes may count for multiple categories.**

ApHC Youth 10 & under W/T

10,81,111,139,145,151,157,162

ApHC Youth All Around:

11,19,24,28,33,38,45,82,102,107,108,112,140,146,152,158,163,166

ApHC Non-pro Walk-Trot:

7,18,32,39,110,114,165,168

ApHC Non-pro 19yrs & Over:

13,20,25,29,34,40,46,83,90,98,103,109,113,116,117,164,167

ApHC Performance Horse:

15,97,106,115,118,169

ApHC Reining/ Working Ranch

21,26,30,35,41,47

ApHC Gaming High Point Non-Pro

141, 147, 153, 159

ApHC Gaming High Point Non-Pro W/T

142, 148, 154, 160

ApHC Gaming High Point Open

138, 144, 150, 156

Open English Exhibitor/Horse

16,121,123,124,125,129,130,132,133,134,136

Open Western Exhibitor/Horse

16,174,175,180,181,182,183,184,185,186

Open Reining/Ranch Horse

23,26,31,36,43,48

Youth Walk Trot E/W 10yrs. & Under

6,84,170a, 177a

Open Jr. Exhibitor 18yrs. & Under

12,84,85,119,126,172,178

Open Sr. Exhibitor 19yrs & Older

14,86,120,127,173,179

Miniature Horse

5,74,96

Driving Horse/ Pony:

95, 99, 100, 101

Open Gaming:

143, 149, 155, 161

The show committee reserves the right to change this listing.

HIGH POINT SHOW AWARDS:

Special awards to 1st and ribbons/prize to 6th in each class.

All classes will be placed through sixth plus a reserve if entries allow.

Points awarded towards high points for placings to 6th

Number in Class	1	2	3	4-8	9-16	17-26	27 & Over
1st Place	1 pt	2 pts	3 pts	6 pts	7 pts	8 pts	9 pts
2nd Place		1pt	2 pts	5 pts	6 pts	7 pts	8 pts
3rd Place			1 pt	4 pts	5 pts	6 pts	7 pts
4th Place				3 pts	4 pts	5 pts	6 pts
5th Place				2 pts	3 pts	4 pts	5 pts
6th Place				1 pt	2 pts	3 pts	4 pts

General Rules

1. **LOSS AND INJURY:** (see 2nd page of entry blank also) The Palouse Empire Appaloosa Club, The Appaloosa Horse Club, Inc., Moscow, Id, Washington State Horsemen, Northeast Zone of Washington State Horsemen's Association, and The Spokane County Fair and Expo Center, Spokane County, their officials, associates, membership, and/or directors shall not be held responsible for any accident that may occur or be caused to or by any horse exhibited at this show, or for any article of any kind or nature that may be lost or in any way damaged. Each exhibitor will be responsible for any injury that may be occasioned to any person or animal or damage to any property while on the grounds by any horse owned, exhibited or in his custody or control and shall indemnify and hold harmless the above named organizations, their officials and directors individually and collectively from and against all claims, demands, causes of action, costs, charges and expenses of every kind and nature whatsoever arising out of which may be incurred by reason of any accident, injury or damage to person or property caused by the ownership, exhibition, custody or control of any animal exhibited. The owner, rider/driver and any of their agents or representatives acknowledge that they participate voluntarily in the competition, fully aware that horse sports and competitions involve inherently dangerous risk, and by participating they expressly assume any and all risks of injury or loss, and they agree to hold harmless the competition and its officials, directors, employees and agents for any injury or loss suffered during or in connection with the competition, whether or not such injury or loss resulted, directly or indirectly from the negligent acts or omissions of said officials, directors, employees or agents. All horses exhibited will be at the owners' risk.

2. **CONTESTANTS ARE RESPONSIBLE FOR KNOWLEDGE OF ALL ApHC APPROVED CLASS RULES, WSH APPROVED CLASS RULES AND OF THE FISTFUL OF SILVER GENERAL SHOW RULES.** The rules governing the individual classes and the formulas for judging percentages used for each class will be found in the current ApHC, WSH or NEZ rulebooks. Presentation of signed entry blank shall be deemed acceptance of said rules, including ApHC drug abuse rules (for ApHC approved classes). If there is failure to sign entry blank, first entry into the ring as an exhibitor shall be deemed acceptance of said rules, including ApHC drug abuse rules (for ApHC approved classes).

3. **ENTRIES:** must be plainly printed or typed and signed by Owner or Authorized Agent, the Rider/Driver/Handler, and any Coach or Trainer. Parent or Guardian signature is required if the Rider/Driver/Handler is a Junior Exhibitor. Numbers will not be released until all required parties have signed the Entry Form. Open Checks will be accepted for entries, and it is the responsibility of the exhibitor to close their open checks. Should exhibitor fail to close out checks, they give PEAC permission to complete the amount of fees due to the club and hold PEAC harmless of any and all liability in doing the same. Riders/Drivers/Handlers sharing the same Horse must each be entered in the show on a separate entry form. Please include photocopies of your: 1) WSH Membership Card, 2) Current ABRA, AMHA, APHA, ApHC, AQHA, PtHA, NRHA, USE, WSH Amateur or Non-Pro Card if entering Amateur designated classes, and 3) Horse's registration papers if entering Breed classes. Please pay only one Stall and/or Tack room, Dry Camp or RV-Hook-Up per Entry Form; please do not split fees or pay another exhibitor's fees on your entry.

4. **CONDUCT:** Show Committee reserves the right to refuse any entry of an exhibitor or participation of any person who has shown an objectionable attitude toward a Recognized Show or previous unsportsmanlike behavior at a Recognized Show or to its Management.

5. ALL HORSES STAYING ON THE GROUNDS OVERNIGHT MUST BE STALLED. THERE WILL BE NO SLEEPING IN THE STALLS. All campers must be in an assigned camping spot. Shavings will be provided. Stall fees \$115 for the weekend (Thursday 3:00 PM - Sunday 6:00pm) two days \$85 and single day stall \$55 (24 hrs. or less). Tack stalls: \$50 weekend or day of \$25. Due to new fairgrounds policy, we will fill the new, large barn first. Special stall requests, including specific stalls or early arrivals, must be made with Show Manager peacoffice1@gmail.com by July 12th, 2024. Stalls assigned on first come first served basis. Stall assignments must be made at the office before stalls may be occupied. If you stall your horse in a stall not assigned to you, you will move your horse and clean and re-bed the stall for the correct occupant.

6. CLOSING DATE for PRE-ENTRIES Entries postmarked after July 12, 2024, will be a one time fee of \$10 charged per rider post entry fee as explained under the fees. All entries must be made on an official entry blank or copy and signed by the proper parties. Entry and stall fees MUST accompany the entry, or it will be treated as a post entry. The show committee may combine or split class divisions.

7. **REFUNDS/JACKPOT MONEY:** No refunds of any nature will be made at the show. All refund requests shall be in the hands of the show secretary before the last class of the show. No refunds will be made on stall or entry fees without a signed vet or doctor's certificate and will be charged a \$10.00 office charge. Refunds will be mailed after checks have cleared the bank, unless applied towards a new entry. Checks for Jackpot payouts will be mailed out to winners within 30 days after the close of the show.

8. **ACCORDING TO FAIRGROUNDS RULES NO DOGS ARE ALLOWED ANYWHERE ON THE GROUNDS EXCEPT FOR THE CAMPING AREA & ALL DOGS MUST BE LEASHED** and owner is responsible for any fines imposed. NO dogs will be allowed in or around the arena including in spectator areas for the safety of riders in the arena.

9. The show reserves the right to refuse entry due to disrespect for the rules, intoxication, rough treatment of animals or for any other reason the management may deem necessary and reasonable. Exhibitors may also be excused from the show or class for the above reasons.

10. **Gate holds** will be granted ONLY if requested at the office at least 3 classes prior to the one being requested for are limited to horses/riders in consecutive classes and shall not exceed three minutes. In classes where horses compete collectively, the gate will be closed two minutes after the first horse enters the ring. An official timer will be appointed to enforce this rule. No horse permitted to enter the ring once the gate is closed.

11. No one shall approach a judge unless he/she first obtains permission from the show committee or show steward, who shall arrange an appointment with the judge at a proper time and place. No exhibitor has the right to inspect the judge's cards without his/her permission. The decision of a Judge is final.

12. NO entry will be accepted where an exhibitor prescribes conditions under which he/she will exhibit.

13. **Checks RETURNED** by the bank for any reason will be charged a \$50.00 penalty, which will be added to the amount owed. Full amount of returned check, plus penalty and all expenses incurred for recovery of debt will be paid in full with cash or money order to show within 10 days of being sent registered mail notification of said check. Debts not paid to show in a timely fashion and returned checks not made good as prescribed will be reported to the ApHC, NEZ and WSH. PEAC BOARD of DIRECTORS will decide whether or not to accept future entries by cash only.

14. Please read all signs on the grounds regarding restricted areas. Motorized vehicles are not allowed in the barn area.

15. Special awards to 1st and ribbons/prizes to 6th in each class. All classes will be placed through sixth plus a reserve if entries allow. Points awarded towards high points for placings to 6th

16. ApHC classes are not WSH "B" system approved or NEZ approved.

17. Per facility requirements, no trailers will be permitted to be parked in a designated fire line. No parking will be permitted between outdoor covered arena and Barn A; no parking permitted between Barn A and Barn B. This will strictly be enforced to stay in compliance with facility mandates. Any trailer found to be hooked up to an electrical facility source will be charged for camping with electrical hook up fee if camping sticker is not displayed. There is a RV dump station located at the fairground. Please contact fairgrounds for additional usage information.

ApHC APPROVED CLASS RULES

1. All horses entered in the ApHC approved classes MUST be registered with the ApHC and eligible to show papers. ALL PERSONS COMPETING IN ANY ApHC SPONSORED OR APPROVED CLASS MUST BE A CURRENT MEMBER OF THE ApHC. Persons entering Non-Pro /Amateur classes must have, or apply for (proof to be shown), a Non-Pro/Amateur endorsement on their current ApHC membership card. If Member cards are not available at the show, person may apply at the show. Registration papers or copies (both sides); AYA, Non-Pro, Amateur and Membership cards or legible copies of said cards MUST be presented at the show office BEFORE numbers are issued. Copies of papers and cards sent with entries are encouraged.

2. Protests applying to any ApHC approved class will be handled in accordance with the current ApHC 2024 rulebook.

3. In all ApHC approved classes, correct exhibitor's numbers must be on their backs in hand classes or on both sides of their saddle pads in riding classes or exhibitor shall be disqualified.

4. No cross entry between ApHC Walk/Trot classes and ApHC Walk, Jog/Trot, Lope/Canter.

5. ApHC Foundation Pedigree Designation; Class Conduct: A. Horses to be judged 40% on color, 60% on confirmation, action, substance, quality, and manners. Horse must have FPD papers to enter this class. No applications for registration or "work in progress" papers. B. Points earned in FPD halter classes will be recorded on the horse's performance record and count toward lifetime awards and year-end medallions.

WSH/NEZ CLASS RULES

1. REGISTRY NUMBER (WSH CLASSES): Full registered name and number is required for entry in classes for registered horses. Papers must be available if requested. A photocopy for show file is appreciated.

2. WSH NON- MEMBER REGISTRATION FEE (WSH CLASSES): A horse/owner or equitation rider/ showmanship handle who is not a WSH member must pay a \$6.00 fee (\$3.00 per judge) at each B System show. A horse owner entering equitation pays one fee. WSH Membership cards must be presented or photocopy with entry. Membership not required by owner of horses ridden in equitation classes; only the equitation rider must be a member or pay the fee. Membership in not required of handlers or riders of horses shown in halter or performance: The owner must be a member or pay the fee.

3. AGE (WSH CLASSES): The age of an individual on Dec. 1, 2023 is maintained the entire year. For horse show purposes, a horse becomes one year old on January 1 following actual foaling date.

4. AMATEUR (WSH/NEZ CLASSES): For amateur classes, current certification from USEF & WSH is required or apply prior to the class for WSH. Fees: Member non-Awards participant \$12.00; Member participating in WSH Awards Program (2 minimum) free. See WSH Steward. The following breed association Non-Pro/Amateur cards, as well as Novice Youth or Youth card for 18 Year olds will also be accepted: WSH/NEZ Horse Shows accept ApHC, ABRA, AQHA, AMHA, APHA, PtHA, NRHA, WSH, USE Amateur Cards/Non-Pro Card
5. CHANGES (WSH/NEZ CLASSES): If three (3) horses are entered prior to a class entering the ring and only one (1) entry comes to the gate, the class will be worked. If two (2) horses are entered prior to a class entering the ring and only (1) entry comes to the gate the class shall be worked. One horse may show and receive one point. Show management is encouraged to run any class that exhibitors have entered and wish to participate. If a class can be combined i.e. an age division with less than three (3) entries, those classes MUST be combined. Should an all-breed class have less than three (3) entries but combining affects the exhibitors' ability to show as a second breed, the actual breed class must be run and not combined, if the exhibitor requests. All horse show classes must be placed 1st through 6th place and a Reserve. All ties must be broken. Classes with less than 3 entries may run concurrently with a like class but, will be scored separately, example: color horse and non color horse..
6. NUMBERS (WSH CLASSES): Exhibitors must appear in the ring suitably attired, with correct number on their backs, or each side of the saddle pad, clearly visible to the judge at all times when in competition. Exception to any "in Hand Class" where the number can be pinned to the front of the exhibitor. Drivers may display number on the vehicle. Entries with incorrect or missing numbers will be eliminated.
7. PROTECTIVE HEADGEAR (WSH/NEZ CLASSES): It is compulsory for all Jr exhibitors 18 and under riding in Hunter attire; Leadline Equitation, Riders 6 & Under (any seat); and Walk/Whoa 8 and Under (any seat) at Washington State Horsemen competitions when mounted anywhere on the competition grounds, to wear properly fastened protective headgear which meets or exceeds ASTM/SEI standards. It is mandatory for anyone of any age to wear properly fastened protective headgear which meets or exceeds ASTM/SEI standards any time jumping on competition grounds
8. PROTESTS (WSH CLASSES): A protest must be written, signed, addressed to the Show Secretary, received by Steward, Show Manager, Show Secretary, or Member of Show Committee within 48 hours of the occurrence of the violation, and accompanied by a \$50.00 deposit, which is forfeited if the objection is not sustained.



Class Descriptions

ALL OTHER BREEDS DIVISION

ALL OTHER BREEDS HALTER, NON-STOCK TYPE, ANY AGE/ANY SEX Shown to Breed type. Class routine to be at the discretion of the Judge.

ALL OTHER BREEDS HALTER, NON-STOCK TYPE, ANY AGE/ANY SEX Shown to Breed type. Class routine to be at the discretion of the Judge.

ALL OTHER BREEDS HALTER, ANY AGE/ANY SEX, CHAMPIONSHIP Shown to Breed type. Class routine to be at the discretion of the Judge.

ALL OTHER BREEDS ENGLISH PLEASURE Tack and attire shall be suitable to horse's type; martingale prohibited. To be shown both ways of the ring at a walk, trot/intermediate gait, and canter. Judged on manners and performance 60%; quality and conformation 30%; suitability of horse to rider 10%.

ALL OTHER BREEDS WESTERN PLEASURE a. Horses are to be shown at a flat footed four-beat walk; free moving easy riding two-beat jog, and three-beat lope both ways of the ring on a reasonably loose rein without undue restraint. Extended gaits may be called for by the Judge. Entries shall be penalized for being on the wrong lead. Special emphasis shall be placed on the walk. Horses may be asked to back at Judge's discretion. All horses chosen for a workout must be worked both ways of the ring at any gait requested by the Judge. To be judged on performance 60%; conformation 30%; and appointments 10%.

APPALOOSA DIVISION

APPALOOSA HALTER HORSE, OPEN Horses shall enter the ring and be lined up at the direction of the Judge. Entries shall be judged individually standing, and also at a walk and trot on the line. Horses shall be led directly to and away from the judge. Additionally, the judge shall inspect the trot from a direct side angle. Horses shall be lined up head to tail for individual inspections by the judge. In all halter classes the judge shall inspect each horse from the front, rear and both sides. Horses should stand squarely and naturally and are not to be stretched. Emphasis shall be placed on type, conformation, action, substance, quality, and manners.

ARABIAN/HALF ARABIAN DIVISION

ARABIAN HALTER HORSE, OPEN HALF-ARABIAN HALTER, OPEN

Horses shall enter the arena at a relaxed walk (four-beat, flat-footed walk) counterclockwise. Each horse shall clear the gate at a walk before striking the trot. Failure to clear the gate at a walk shall require horse to re-enter at a proper walk, and then strike a trot until reaching its designated position in line. Horses shall then walk counterclockwise or clockwise at the discretion of the Judge in a relaxed manner on a loose lead with the handler at the side of the horse, whips down. All horses to walk on the rail in each direction past each Judge. Horses shall then be presented to the Judge individually, standing correctly with weight on all four feet, in a quiet, deliberate manner. There shall be no contact of the whip to the horse. Any contact shall result in elimination. Judged on type, conformation, suitability as a breeding animal (except geldings), quality, movement, substance, manners, and presence.

ARABIAN ENGLISH PLEASURE, OPEN To be shown at a walk, normal trot, strong trot, canter, and hand gallop. Judged on manners, performance, attitude, quality, and conformation.

HALF-ARABIAN ENGLISH PLEASURE, MARES & GELDINGS To be shown at a walk, normal trot, strong trot, canter, and hand gallop. Judged on manners, performance, attitude, quality, and conformation.

ARABIAN WESTERN PLEASURE, OPEN To be shown at a walk, jog, lope, and hand gallop. Extreme speed to be penalized. Judged on manners, performance, substance, quality, and conformation.

HALF-ARABIAN WESTERN PLEASURE, MARES & GELDINGS To be shown at a walk, jog, lope, and hand gallop. Extreme speed to be penalized. Judged on manners, performance, substance, quality, and conformation.

QUARTER HORSE DIVISION

QUARTER HORSE HALTER, ANY AGE, ANY SEX Horses will walk to the Judge one at a time. As the horse approaches, the Judge will step to the right (left of the horse) to enable horse to trot straight to a cone placed at 50 feet away. At the cone, the horse will continue trotting, turn to the left, and trot toward the left wall or fence of the arena. After trotting, horses will be lined up head to tail for individual inspection by the Judge. The Judge shall inspect each horse from both sides, front and rear. Judged on balance, structural correctness, degree of muscling, and breed and sex characteristics. Balance is the single most important factor. When Quarter Horse Halter is offered during the same session as English Showmanship, the English attire and halter will be allowed.

QUARTER HORSE HUNTER UNDER SADDLE Not to jump. Horses to be shown under saddle at a walk, trot and canter both ways of the ring. Horses should back easily and stand quietly. Horses may change gaits at the flat footed walk or trot at the Judge's discretion. Light contact with the horse's mouth is recommended. At the option of the Judge, all or just the top 12 may be required to hand gallop one or both ways of the ring. Never more than 12 to hand gallop at one time. At the hand gallop, Judge may ask group to halt and stand quietly on a free (loosened rein). Judged on performance, condition and conformation of the horse, however a minimum of 20% of the judging shall be based on condition and conformation. Maximum credit shall be given to the flowing, balanced, willing horse.

QUARTER HORSE WESTERN PLEASURE To be shown at a walk, jog and lope both ways of the ring on a reasonably loose rein, or light contact, without undue restraint. Horses must lope with forward motion. Horses must back easily and stand quietly. It is mandatory that a moderate extension of the jog be asked for in at least one direction of the ring (except youth 13 & under classes, where it is optional). Judged on performance and conformation of the horse at the discretion of the Judge; however, a minimum of 20% of the judging shall be based on condition and conformation. Maximum credit shall be given to the flowing, balanced, and willing horse.

DRIVING DIVISION

PLEASURE DRIVING, GREEN HORSE/PONY 1st/ 2nd YR First or second year of showing in Driving Classes at USEF/Equine Canada/WSH and/or Breed Approved Shows. No trot on/increased intermediate gait. To enter the ring in harness at a trot/intermediate gait. To be shown at a flat-footed walk, working trot/intermediate gait, both ways of the ring, with emphasis on the flat-footed walk. To stand quietly. May be asked to back. Judged 70% on manners, performance, condition, and style; 20% on fit, condition and appropriateness of harness and vehicle; and 10% on conformation.

PLEASURE DRIVING HORSE/PONY, OPEN

PLEASURE DRIVING HORSE/PONY, OPEN CHAMPIONSHIP Counting points from: Open, & Championship Classes. To enter the ring in harness at a trot/intermediate gait. To be shown at a flat-footed walk, working trot/intermediate gait, and trot on/increased intermediate gait (extreme speed to be penalized) both ways of the ring. Emphasis on the flat-footed walk. To stand quietly. May be asked to back. Judged 70% on manners, performance, condition, and style; 20% on fit, condition and appropriateness of harness and vehicle; and 10% on conformation. Qualifying class #100

REINSMANSHIP, OPEN This class is designed to test the knowledge and ability of the driver. To be conducted in the manner of an Open Pleasure Driving Class. To be judged as an equitation class on hands, proper harnessing and hitching, and correct driving techniques. Tests are required.

Reinsmanship Tests:

1. Back.
2. Drive in a circle of designated size at Judge's discretion.
3. Drive a figure-eight.
4. Extended trot/intermediate gait.
5. Negotiate simple obstacles, e.g. drive between two obstacles.
6. Pivots of 90, 180, and/or 360 degrees with inside wheel in place; left or right.
7. Back between two markers.
8. Extended walk.

ENGLISH DIVISION

ENGLISH PLEASURE, GREEN HORSE, 1st/ 2nd Yr WTC. Eligibility requirements are based on a horse's prior participation in English classes at USE/Equine Canada/WSH and/or Breed recognized shows prior to the current year. For horses in their first or second year of showing under English tack in USE/Equine Canada/WSH and/or Breed Association recognized shows. Horses of any age may be shown in standard English tack. Tack and attire shall be suitable to horse's type; martingales and training equipment prohibited. To be shown at a walk, trot/intermediate gait, and canter both ways of the arena. No extension of gaits shall be called for. Shall not be asked to gallop or reverse at the canter. May be asked to back. Judged 60% on performance, 30% on conformation, and 10% on appointments. Cross entry is permitted into walk/trot and 3 gait classes.

ADVANCED ENGLISH PLEASURE To be shown at a walk, trot and canter. A minimum of three (3) or more additional tests must be included. Some examples of tests, but not limited to, may include the following: extension of gait, collection of gait, forehand/haunch turn, back, change direction, sidepass, loose rein, shoulders in/out, leg yield, 10 meter circle, counter canter and/or perform any other tests indicative of a highly trained pleasure horse. If a reverse at the canter is called for, exhibitors shall reverse and proceed on the lead specified by the judge. All horses must be allowed to attempt all requested tests. Horses should be agile, athletic, supple, prompt and willing, and show impulsion with calmness and good manners. Judged on performance and manners. *No dropping of irons shall be permitted.

ENGLISH PLEASURE, COLORED HORSES Open to Albino, Appaloosa, Buckskin, Dun, Grulla, Paint, Palomino, and Pinto horses who are not shown in Non-Color Class English. Horses must show a recognizable coat and/or color pattern from a distance. Tack and attire shall be suitable to horse's type; martingale prohibited. To be shown at a walk, trot/intermediate gait, and canter, both ways of the ring. Light contact with the horse's mouth shall be maintained. Judged 40% on colorful qualities, 40% on performance, way of going and manners, and 20% on conformation.

ENGLISH PLEASURE, NON-COLORED HORSES Open to horses who are not shown in Color Class English. Martingale prohibited. To be shown according to Breed type at a flat-footed walk, trot/ intermediate gait and easy canter. Light contact must be maintained. Judged 80% on manners and performance, with emphasis on a pleasurable ride, and 20% on conformation.

ENGLISH PLEASURE HORSE, JUNIOR EXHIBITOR, 18 YEARS & UNDER

ENGLISH PLEASURE HORSE, SENIOR EXHIBITOR, 19 YEARS & OVER

ENGLISH PLEASURE, OPEN

ENGLISH PLEASURE, JUNIOR HORSE 5 YEARS & UNDER (WSH POINTS TO OPEN)

ENGLISH PLEASURE, JUNIOR HORSE 6 YEARS & OVER (WSH POINTS TO OPEN) Tack and attire shall be suitable to horse's type; martingale prohibited. To be shown both ways of the ring at a walk, trot/intermediate gait, and canter. Judged on manners and performance 60%, quality and conformation 30%, and suitability of horse to rider 10%.

ENGLISH PLEASURE, GREEN HORSE, 1st/ 2nd Yr., W/T Eligibility requirements are based on a horse's prior participation in any type English or Hunter classes at USEF/Equine Canada/WSH and/or Breed recognized shows prior to the current year with any owner. For horses in their first or second year of showing under English tack in USEF/ Equine Canada/WSH and/or Breed Association recognized shows. Horses of any age may be shown in standard English tack. Tack and attire shall be suitable to horse's type; martingales and training equipment prohibited. To be shown both ways of the ring at a walk, trot/intermediate gait both ways of the arena. No extension of gaits shall be called for. May be asked to back. Judged on manners and performance 60%, quality and conformation 30%, and suitability of horse to rider 10%. May cross enter to walk, trot, canter classes.

ENGLISH PLEASURE, LIMIT HORSE W/T Open to horses who have not won six firsts in English Pleasure. Tack and attire shall be suitable to horse's type, martingale prohibited. To be shown both ways of the ring at a walk and trot/intermediate gait. Judged on manners and performance 60%, quality and conformation 30% and suitability of horse to rider 10%. Cross entry is permitted into walk/trot and 3 gait classes.

ENGLISH PLEASURE, LIMIT HORSE Open to horses who have not won six firsts in English Pleasure. Tack and attire shall be suitable to horse's type, martingale prohibited. To be shown both ways of the ring at a walk, trot/intermediate gait, and canter. Judged on manners and performance 60%, quality and conformation 30% and suitability of horse to rider 10%. Cross entry is permitted into walk/trot and 3 gait classes.

EQUITATION DIVISION

LEADLINE EQUITATION (E/W), RIDERS 6 & UNDER Recommend ribbons to eight (8) places; participation ribbons to all. Saddle Seat, Hunter Seat, or Western Seat tack and appointments. Hooded stirrups are permitted. **Riders to wear an ASTM/SEI approved helmet properly fitted with harness in place at all times when mounted.** Spurs are prohibited. To be led from the ground by a Senior (19 & over). Horse to be led by lead shank attached to a halter. To be shown both ways of the ring at a walk only. Rider may not be tied in the saddle in any way. If feet are not in the stirrups, the exhibitor may be penalized. Judged on seat, hands, and general horsemanship. Suitability of mount to rider to be considered. No cross entry to any other ridden/driven class in the show, except Leadline Trail. Leadline riders may enter 10 & under showmanship. The lead person should conform to proper English or Western attire and be consistent with the rider. (Note: Cross entry restriction is on the rider; it does not apply to the horse.)

SHOWMANSHIP IN HAND, ENGLISH OR WESTERN, JUNIOR EXHIBITOR 13 YEARS & UNDER

SHOWMANSHIP IN HAND, ENGLISH OR WESTERN, JUNIOR EXHIBITOR 14-18 YEARS

SHOWMANSHIP IN HAND, ENGLISH OR WESTERN, SENIOR AMATEUR, 19 YEARS & OVER

Exhibitors will be asked to demonstrate their ability to lead, turn, set-up and move their animals as the Judge directs. The Judge may ask exhibitors to perform other tests. Judges' techniques and procedures will vary. The following principles always apply: individual tests must be performed with Official(s) involved in the test in the same relative position to each exhibitor. The exhibitor shall not stand directly in front of the horse. The exhibitor shall always lead, back, or move the horse from the left (near) side, unless otherwise specified in the pattern. All turns of 180 degrees or more shall be to the right, with the exhibitor walking to the right around the horse. Forehand turns of any degree to either direction are permissible. Quartering system is recommended but not mandatory. Judges may penalize at their discretion any exhibitor that does not demonstrate the quartering system. Horses may be shown according to breed type. Judged 60% on showmanship and handling, 30% on fitting and grooming, 10% on neatness of handler (points to handler). Shows may combine English and Western Showmanship. If separated, both must be offered. **Hunter Seat:** Appropriate Hunter attire and horses are to be shown in a Hunter bridle or plain leather halter. Spurs, crops or bats are prohibited. **Saddle Seat:** Appropriate Saddle Seat Attire and horses are to be shown in an appropriate bridle or show halter, whips are permitted. Spurs are prohibited. **Western:** Western attire and appropriate show halter to be used. Chaps and spurs are prohibited.

WALK /WHOA EQUITATION, ENGLISH OR WESTERN, RIDERS 8 YRS. & UNDER Saddle Seat, Hunter, or Western Seat tack and appointments. Hooded stirrups are permitted. Riders to wear an ASTM/SEI approved helmet properly fitted with harness in place at all times when mounted. Spurs are prohibited. To be shown both ways of the ring at a walk only. Riders to be asked to halt their mounts on the rail each way of the ring, and back a few steps in the line-up. Judged on seat, hands, and general horsemanship. Suitability of mount to rider to be considered. No cross entry to any other ridden/driven class in the show except 10 & Under showmanship. (Note: Cross entry restriction is on the rider and does not apply to the horse.)

SHOWMANSHIP IN HAND, ENGLISH OR WESTERN, LIMIT HANDLER, JUNIOR EXHIBITOR & SENIOR AMATEUR Open to exhibitor with less than 6 first places in WSH/CEF/USEF/Breed approved shows. Exhibitors will be asked to demonstrate their ability to lead, turn, set-up and move their animals as the Judge directs. The Judge may ask exhibitors to perform other tests. Judges' techniques and procedures will vary. The following principles always apply: individual tests must be performed with Official(s) involved in the test in the same relative position to each exhibitor. The exhibitor shall not stand directly in front of the horse. The exhibitor shall always lead, back, or move the horse from the left (near) side, unless otherwise specified in the pattern. All turns of 180 degrees or more shall be to the right, with the exhibitor walking to the right around the horse. Forehand turns of any degree to either direction are permissible. Quartering system is recommended but not mandatory. Judges may penalize at their discretion any exhibitor that does not demonstrate the quartering system. Horses may be shown according to breed type. Judged 60% on showmanship and handling, 30% on fitting and grooming, 10% on neatness of handler (points to handler). Shows may combine English and Western Showmanship. If separated, both must be offered. **Hunter Seat:** Appropriate Hunter attire and horses are to be shown in a Hunter bridle or plain leather halter. Spurs, crops or bats are prohibited. **Saddle Seat:** Appropriate Saddle Seat Attire and horses are to be shown in an appropriate bridle or show halter, whips are permitted. Spurs are prohibited. **Western:** Western attire and appropriate show halter to be used. Chaps and spurs are prohibited.

HUNTER SEAT EQUITATION, JR. EX. 18 & UNDER

HUNTER SEAT EQUITATION, SR. AM. 19& over (Stallions Permitted)

HUNTER SEAT EQUITATION (NOT TO JUMP) Jr Ex & Sr Am Championship

Competitors shall enter the ring and proceed around the ring at each gait and, on command, reverse and repeat. Riders may be asked to work collectively without stirrups in 14 & over and open classes. The order to reverse can be executed by turning toward or away from the rail. Light contact with horse's mouth is required. Entries then line up on command. Any or all riders may be required to execute any appropriate tests included in class requirements. Tests must be on the flat. Judges are encouraged to call for at least two tests of the top contestants. Options: a. Rail work showing three gaits (two for w/t) both directions and a back up either on the rail or in line up. b. Pattern work only, with no rail work required. c. A combination of pattern & rail work.

EQUITATION, WALK/TROT E/W RIDERS 10 & UNDER

Hunter Seat, Saddle Seat or *Western* Seat (chaps optional), Hooded stirrups permitted. To be shown both ways of the ring at a walk and jog/trot/intermediate gait. Not to canter/lope. Judged on seat, hands, and general horsemanship. Suitability of mount to rider to be considered. Rider may not cross enter to any lope or canter classes in the same show, except W/T Pleasure, Limit W/T or W/J Equitation or Pleasure and W/T Trail Classes. (Note: Cross entry restriction is on the rider; it does not apply to the horse.) Recommend ribbons to eight places: participation ribbons to all.

WESTERN EQUITATION, LIMIT RIDER JR/SR AM, W/J Riders enter the ring at a walk or jog/intermediate gait and are judged at a flat-footed four beat walk and two beat jog/intermediate gait both ways of the ring. Judged on hands, seat and suitability of horse to rider. Cross entry is permitted into walk/trot and 3 gait classes.

WESTERN SEAT EQUITATION

WESTERN SEAT EQUITATION JR. EX. 18 & under

WESTERN SEAT EQUITATION SR. AM. 19& Over (Stallions Permitted)

Riders enter the ring at a walk or jog/intermediate gait and are judged at a flatfooted four beat walk, two beat jog/intermediate gait, and a three beat lope both ways of the ring. The order to reverse may be executed by turning toward or away from the rail. All competitors are required to WSH 2024 RULE BOOK 99 back in a straight line during the line up or on the rail. Judges are encouraged to call for a least two tests to be performed by competitors being considered for an award. Due to the difficulty of properly fitting tack, riders shall not be asked to change horses. Results as shown by the performance of the horse are not to be considered more important than the method used to obtaining them. Riders will be judged on seat, hand, performance of horse, appointments of horse and rider, and suitability of horse to rider. Female riders astride may wear split skirts. Acceptable bits to include Standard Western bits. Snaffles and Bosals for Junior horses 5 and Under, with rider using two hands is permissible. Options: a. Rail work showing three gaits (two for w/t) both directions and a backup either on the rail or in line up. b. Pattern work only, with no rail work required. c. A combination of pattern & rail work.

BAREBACK HORSEMANSHIP, ENGLISH OR WESTERN, JR/SR AM Walk/Trot Riders to wear appropriate English or Western riding apparel. Horses are to be worked both ways of the ring at a walk, jog/trot/intermediate gait. Riders may be asked for any additional tests the Judge may deem necessary. Riders shall not be asked to dismount and mount. Judged on hands, seat and suitability of horse to rider. Rail work showing two gaits both directions and a back either on the rail or in line up. Not a WSH.

BAREBACK HORSEMANSHIP, ENGLISH OR WESTERN, JR/SR AM Riders to wear appropriate English or Western riding apparel. Horses are to be worked both ways of the ring at a walk, jog/trot/intermediate gait, and canter/lope, and shall always be on the correct lead. Riders may be asked for any additional tests the Judge may deem necessary. Riders shall not be asked to dismount and mount. Judged on hands, seat and suitability of horse to rider. Options: a. Rail work showing three gaits both directions and a back either on the rail or in line up. b. Pattern work only, with no rail work required. c. A combination of pattern & rail work

MINIATURE DIVISION

MINIATURE HORSE PLEASURE DRIVING, 38" & UNDER Open to all horses 38" & Under. Specifications of Pleasure Driving Horse, Open. To enter the ring in harness at a trot/intermediate gait. To be shown at a flatfooted walk, working trot/intermediate gait, and trot on/increased intermediate gait (extreme speed to be penalized) both ways of the ring with emphasis on the flat-footed walk. To stand quietly and back readily. Judged 70% on manners, performance, condition and style; 20% on fit, condition and appropriateness of harness and vehicle; and 10% on conformation.

MINIATURE HORSE HALTER, 38" & UNDER, ANY AGE, ANY SEX To be shown in hand at a walk and trot. Horses must also be viewed in motion from the side. To be shown square, not stretched, which means all four feet are flat on the ground and at least one front, and one rear cannon bone is perpendicular to the ground. Horses may be shown clipped or in full coat. Horses must be serviceably sound, in good condition, and well-groomed. Transmissible weakness and unsoundness to be penalized. Judges must check teeth in all horses, except geldings. In no case shall a smaller horse be placed over a larger animal with better conformation. To be judged on conformation, quality, presence, way of going, and type.

MINIATURE HORSE OBSTACLE IN HAND, 38" & UNDER Class to include no less than five (5) or more than eight (8) obstacles. They should be interesting, inviting, and safe for both horse and handler. Obstacles may include but need not be limited to back through, 106 WSH 2024 RULE BOOK side pass, walk over plastic, walk through water, ground tie (only in a safe enclosed arena), jump (not to exceed one foot in height), and serpentine through obstacles. Horses should not be penalized for hesitating and showing interest in an obstacle. Handlers not required to negotiate the obstacles. Judged as a Trail horse class. NOTE: Mandatory dimensions of obstacles will not apply to Miniatures due to the size of the horse. NOTE: Although entries will not be timed, it is recommended that the course can be completed within two minutes.

MISCELLANEOUS DIVISION

LONGE LINE, 3 Yrs & UNDER

- a. To be shown in a regular type halter with only a longe line attached by the snap. A longe whip is permitted.
- b. Use of circle is necessary and should be 25-foot radius.
- c. Personal attire and appointments should be that of Halter or Showmanship. English prospects may be braided.
- d. Judge to be outside the longeing circle.
- e. At the signal each exhibitor will have 90 seconds to individually present his horse, starting in either direction. The horse should demonstrate a walk, jog/trot and lope/canter each direction. Playing on the line not to be penalized. This class is to reward movement, manners/expression/ attitude and conformation. Judged as a pleasure prospect. May be penalized for excessive bucking, charging, or displaying traits undesirable in pleasure horses, (e.g., pinning ears or wringing tail).
- f. Bleeding, raw or broken skin will eliminate an entry.
- g. Exhibitors remain in the ring after showing.
- h. Judged on movement 60%; manners 20%; conformation 20% Balance and athletic capabilities are to be emphasized.
- i. Equines shown in longe line cannot be crossed entered into riding classes at the same show. May be shown in other in hand classes.
- j. An exhibitor will only show one (1) horse.

TRAIL DIVISION

TRAIL HORSE IN HAND, ADOLESCENT THREE YEARS & UNDER Horses and ponies, three years and under, that are in their first year of being broken to saddle or have never been ridden. Cross entry to any other riding Trail class is prohibited. The handler will lead the horse/pony through, over, and around the obstacles. Touching the horse will be penalized, but not necessarily disqualified. Horse shall be shown in a halter. Personal appointments are optional for the handler. To be shown at a walk and trot. Obstacles will be according to WSH Western Division. An Exhibitor/horse who has a major fault may not place over a horse/ exhibitor with any minor faults. All horses/exhibitors eligible will be placed.

TRAIL IN HAND, JUNIOR EXHIBITOR 18 YEARS & UNDER Open to any age or breed of horse, pony or mule. Cross entry to any other riding Trail class is allowed. The handler will lead the horse/pony/ mule through, over and around the obstacles. Touching the horse will be penalized, but not necessarily disqualified. Horse shall be shown in a halter. Personal appointments are optional for the handler. To be shown at a walk and a trot. Obstacles will be according to WSH Western Division. An Exhibitor/horse who has a major fault may not place over a horse/exhibitor with any minor faults. All horses/exhibitors eligible will be placed.

TRAIL IN HAND, OPEN Open to any age or breed of horse, pony or mule. Cross entry to any other riding Trail class with the same exhibitor is prohibited. The handler will lead the horse/pony/mule through, over and around the obstacles. Touching the horse will be penalized, but not necessarily disqualified. Horse shall be shown in a halter. Personal appointments are optional for the handler. To be shown at a walk and a trot. Obstacles will be according to WSH Western Division. An Exhibitor/horse who has a major fault may not place over a horse/exhibitor with any minor faults. All horses/exhibitors eligible will be placed.

TRAIL HORSE, ENG./WEST., GREEN 1st/2nd YEAR, WALK/JOG For horses in their first or second year of showing in Trail under saddle in USE/Equine Canada/WSH and/or breed association recognized shows. To be shown over and through obstacles at a walk, trot/jog/intermediate gait, and canter/lope on a reasonably loose rein without undue restraint. May be conducted as a walk/trot class. Cross entry to other trail classes allowed. An Exhibitor/horse who has a major fault may not place over a horse/exhibitor with any minor faults. All horses/exhibitors eligible will be placed.

MARIANN BONWELL WALK-TROT TRAIL, ENG./WEST., RIDERS 10 & UNDER For beginning riders 10 and under who are qualified to walk and jog/trot their horses. English or western tack and appointments. Hooded stirrups permitted. Chaps are optional. To be shown through a course of obstacles at the walk and jog/trot/intermediate gait. Not to be asked to canter, dismount, or mount. No cross entry of riders to any three-gaited classes. (Note: cross entry restriction is on the rider; it does not apply to the horse.) The course designer is requested to take the age of the riders into consideration. An Exhibitor/horse who has a major fault may not place over a horse/exhibitor with any minor faults. All horses/exhibitors eligible will be placed.

TRAIL HORSE, ENGLISH OR WESTERN, LIMIT RIDER WALK-TROT Open to riders who have not won six firsts in trial in recognized shows prior to the current year. To be shown over and through obstacles at a walk, trot/jog/intermediate gait, on a reasonably loose rein without undue restraint. Cross Entry allowed to age group, but not with Trail In Hand Open, this applies to horse. An Exhibitor/horse who has a major fault may not place over a horse/exhibitor with any minor faults. All horses/ exhibitors eligible will be placed. **No WSH PTS**

TRAIL HORSE, ENGLISH OR WESTERN, JUNIOR EXHIBITOR, 18 YEARS & UNDER

TRAIL HORSE, ENGLISH OR WESTERN, SENIOR EXHIBITOR, 19 YEARS & OVER

TRAIL HORSE, ENGLISH OR WESTERN, Jr Ex & Sr Ex, Championship

English or Western tack and appointments. To be shown over and through obstacles at a walk, trot/jog/intermediate gait, and canter/lope, on a reasonably loose rein without undue restraint. Cross Entry NOT allowed between age groups, this applies to both horse and rider. An Exhibitor/ horse who has a major fault may not place over a horse/exhibitor with any minor faults. All horses/exhibitors eligible will be placed.

WESTERN DIVISION

ADVANCED WESTERN PLEASURE To be shown at a walk, jog and lope. A minimum of three (3) or more additional tests must be included. Some examples of tests, but not limited to, may include the following: extension of gait, collection of gait, forehand/haunch turn, back, change direction, sidepass, loose rein, shoulders in/out, leg yield, 10 meter circle, counter lead at the lope and/or perform any other tests indicative of a highly trained pleasure horse. If a reverse at the lope is called for, exhibitors shall reverse and proceed on the lead specified by the judge. All horses must be allowed to attempt all requested tests. Horses should be agile, athletic, supple, prompt and willing, and show impulsion with calmness and good manners. Judged on performance and manners. *No dropping of stirrups shall be permitted.

WESTERN PLEASURE, COLORED HORSES Open to Albinos, Appaloosas, Buckskins, Duns, Grullas, Paints, Palominos and Pintos, who are not shown in Non-Color Western. Horses must show a recognizable coat and/or color pattern from a distance. To be shown according to Breed type at a walk, jog/ intermediate gait, and lope, both ways of the ring on a reasonably loose rein, without undue restraint. Special emphasis on the walk. Judged 40% on colorful qualities, 40% performance and manners, and 20% on conformation.

WESTERN PLEASURE, NON-COLORED HORSES Open to horses who are not shown in Color Class Western. To be shown according to Breed type at a walk, jog/ intermediate gait, and lope, both ways of the ring on a reasonably loose rein, without undue restraint. Special emphasis on the walk. Judged on performance 60%, conformation 30%, and appointments 10%.

WESTERN PLEASURE, GREEN HORSE, 1st & 2nd Yr. W/J Eligibility requirements are based on participation in Western classes at USEF/Equine Canada/WSH and/or Breed recognized shows prior to the current year. For horses in their first or second year of showing under Western tack in USEF/Equine Canada/WSH and/or Breed Association recognized shows. USEF Western Equipment rules apply, regarding tack and attire, except, horses of any age may be shown in a standard Western bit (with one hand only) or in a ring snaffle or standard rawhide hackamore (two hands permitted). Tack and attire shall be suitable to horse's type; martingales and training equipment are prohibited. To be shown at a walk, and jog/intermediate gait, both ways of the arena. No extension of gaits shall be called for. May be asked to back. Judged 60% on performance, 30% on conformation, and 10% on appointments.

WESTERN PLEASURE, GREEN RIDER, 1st & 2nd Yr., W/J Eligibility requirements are based on a rider's prior participation in any type Western Pleasure classes at USEF/Equine Canada/WSH and/or Breed recognized shows prior to the current year. For riders in their first or second year of showing under Western tack in USEF/Equine Canada/WSH and/or Breed Association recognized shows except, horses of any age may be shown in a standard Western bit (with one hand only) or in a ring snaffle or standard rawhide hackamore (two hands permitted).

Tack and attire shall be suitable to horse's type; martingales and training equipment prohibited. To be shown both ways of the ring at a walk, jog/intermediate gait. No extension of gaits shall be called for. May be asked to back. Judged on manners and performance 60%, quality and conformation 30%, and suitability of horse to rider 10%. May cross enter to walk, jog classes.

WESTERN PLEASURE, GREEN HORSE, 1st & 2nd Yr. Eligibility requirements are based on a horse's prior participation in any type Western Pleasure classes at USEF/Equine Canada/WSH and/or Breed recognized shows prior to the current year with any owner. For horses in their first or second year of showing under Western tack in USEF/Equine Canada/WSH and/or Breed Association recognized shows except, horses of any age may be shown in a standard Western bit (with one hand only) or in a ring snaffle or standard rawhide hackamore (two hands permitted). Tack and attire shall be suitable to horse's type; martingales and training equipment prohibited. To be shown both ways of the ring at a walk, jog/intermediate gait and lope. No extension of gaits shall be called for. May be asked to back. Judged on manners and performance 60%, quality and conformation 30%, and suitability of horse to rider 10%. May cross enter to walk, jog, lope classes.

WALK TROT, E/W PLEASURE, RIDERS 10 & UNDER

Riders may not cross enter to any lope or canter class in the same show. (Note: Cross entry restriction is on the rider; it does not apply to the horse.) Hunter seat, Saddle Seat or Stock Seat tack and appointments (chaps optional); hooded stirrups permitted. To enter at the walk and be shown both ways of the ring at a walk and jog/trot/ /intermediate gait; not to canter. Judged on suitability as a child's first mount 40%, manners 40%, and performance 20%.

WESTERN PLEASURE HORSE, JUNIOR EXHIBITOR, 18 YEARS & UNDER

WESTERN PLEASURE, SENIOR EXHIBITOR, 19 YEARS & OVER

Horses are to be shown at a flat-footed, four-beat walk; free moving easy riding two-beat jog, and three-beat lope both ways of the ring on a reasonably loose rein without undue restraint. Extended gaits may be called for by the Judge. Special emphasis shall be placed on the walk. Horses may be asked to back at Judge's discretion. All horses chosen for a workout must be worked both ways of the ring at any gait requested by the judge. To be judged on performance 60%; conformation 30%, and appointments 10%.

WESTERN PLEASURE, JUNIOR HORSE, 5 YEARS & UNDER (WSH PTS TO OPEN)

WESTERN PLEASURE, SENIOR HORSE, 6 YEARS & OVER (WSH PTS TO OPEN) Horses are to be shown at a flat-footed, four-beat walk; free moving easy riding two-beat jog, and three-beat lope both ways of the ring on a reasonably loose rein without undue restraint. Extended gaits may be called for by the Judge. Special emphasis shall be placed on the walk. Horses may be asked to back at Judge's discretion. All horses chosen for a workout must be worked both ways of the ring at any gait requested by the Judge. To be judged on performance 60%; conformation 30%, and appointments 10%.

WESTERN PLEASURE OPEN Horses are to be shown at a flat-footed, four-beat walk; free moving easy riding two-beat jog, and three-beat lope both ways of the ring on a reasonably loose rein without undue restraint. Extended gaits may be called for by the Judge. Special emphasis shall be placed on the walk. Horses may be asked to back at Judge's discretion. All horses chosen for a workout must be worked both ways of the ring at any gait requested by the judge. To be judged on performance 60%; conformation 30%, and appointments 10%.

WESTERN PLEASURE, LIMIT HORSE Horses are to be shown at a flat-footed, four-beat walk; free moving easy riding two-beat jog and three-beat lope both ways of the ring on a reasonably loose rein without undue restraint. Extended gaits may be called for by the Judge. In pleasure classes special emphasis shall be placed on the walk. Horses may be asked to back at Judge's discretion. All horses chosen for a workout must be worked both ways of the ring at any gait requested by the Judge. To be judged on performance 60%; conformation 30%, and appointments 10%. Cross entry is permitted into walk/trot and 3 gait classes.

REINING DIVISION

REINING, OPEN (NRHA PATTERN #7) To rein a horse is not only to guide him, but also to control his every movement. The best reined horse should be willingly guided or controlled with little or no apparent resistance and dictated to completely. Any movement on his own must be considered a lack of control. All deviations from the exact written pattern must be considered a lack of/or temporary loss of control and therefore a fault that must be marked down according to severity of deviation. After deducting all faults, set here within, against execution of the pattern and the horse's overall performance, credit should be given for smoothness, finesse, attitude, quickness and authority of performing various maneuvers, while using controlled speed which raises the difficulty level and makes him more exciting and pleasing to watch to an audience. The official guideline for the application for the rules for judging shall be as specified in the NRHA Judges Guide. Participants may obtain points from unrecognized Reining events by signing up with the WSH Horse Show Division. A ZERO (0) score may place and receive a ribbon but not above another exhibitor that did not receive a ZERO (0) score.

RANCH HORSE DIVISION

RANCH HORSE TRAIL The ranch trail class should test the horse's ability to cope with situations encountered while being ridden through a pattern of obstacles generally found during the course of everyday ranch work. The horse/rider team is judged on the correctness, efficiency and pattern accuracy with which the obstacles are negotiated, and the attitude and mannerisms exhibited by the horse. Judging emphasis is on identifying the well broke, responsive and well mannered horse which can correctly navigate and negotiate the course. The ideal ranch trail horse should have a natural ranch horse appearance from head to tail in each maneuver. The ranch trail course will include no less than six and no more than nine obstacles. It is mandatory that the horse be asked to walk, trot and lope during the course. Care must be exercised to avoid setting up any obstacles that may be hazardous to the horse or rider. When setting courses, management will be mindful that the idea is not to trap a horse/rider team or eliminate it by making an obstacle too difficult. All courses and obstacles are to be constructed with safety in mind so as to reduce the risk for accidents. Show committee shall have the option of setting up the trail course to best fit the arena conditions. Judges must walk the course and have the right and duty to alter the course if it is not in keeping with the intent of the class. Judges may remove or change any obstacles they deem unsafe, non-negotiable or unnecessarily difficult. Any time a trail obstacle becomes unsafe during a class, it shall be repaired or removed from the course. If the course cannot be repaired and some horses have completed the course, the score for that obstacle shall be deducted from all previous draws in that class. A horse with a major fault may not place above or over a horse with minor fault(s).

RANCH HORSE TRAIL Walk/Trot All Ages Exhibitors may not be asked to lope. Same horse/rider combination may not cross enter to three (3) gaited classes. (No NEZ points)

RANCH HORSE TRAIL, Open (No NEZ points)

RANCH RIDING, Limited Walk/Trot (No NEZ points) Not to lope

RANCH RIDING, Open (points go to age division) The purpose of Ranch Riding horse should reflect the versatility, attitude, and movement of a working horse. The horse's performance should simulate a horse riding outside the confines of an arena and that of a working ranch horse. This class should show the horse's ability to work at a forward and working speed while under control by the rider. Light contact should be rewarded, and horse shall not be shown on a full drape of reins. Allow posting and holding the saddle horn. The horse's head position should be elevated and above the level at all gaits. The overall manners and responsiveness of the horse while performing the maneuver requirements, and the horse's quality of movement are the primary considerations. Horse may not have won six (6) firsts in Ranch Riding.

RANCH RAIL OPEN, JR/SR EX W/J Horses competing in Ranch Rail class should reflect the versatility, attitude, and movement of a working horse. The horse's performance should simulate a horse riding outside the confines of an arena and that of a working ranch horse. This class should show the horse's ability to work at a forward and working speed while under control by the rider. Light contact should be rewarded and horse shall not be shown on a full drape of reins. Allow posting and holding the saddle horn. The horse's head position should be elevated and above the level at all gaits. The overall manners and responsiveness of the horse while performing the maneuver requirements, and the horse's quality of movement are the primary considerations. The class will be worked both directions of the arena. Exhibitors will be asked to walk, extend the walk, jog, extend the jog, stop from any gait, back, side pass to and from the rail, and turn of 180 degrees or greater. Any class size greater than 8 may be worked in lots at show management or judge's discretion depending on arena capacity and safety. No cross entry to three (3) gait classes same horse/rider combination. Sponsor Willie Hansen

RANCH RAIL OPEN Horses competing in Ranch Rail class should reflect the versatility, attitude, and movement of a working horse. The horse's performance should simulate a horse riding outside the confines of an arena and that of a working ranch horse. This class should show the horse's ability to work at a forward and working speed while under control by the rider. Light contact should be rewarded, and horse shall not be shown on a full drape of reins. Allow posting and holding the saddle horn. The horses head position should be elevated and above the level at all gaits. The overall manners and responsiveness of the horse while performing the maneuver requirements, and the horse's quality of movement are the primary considerations. The class will be worked both directions of the arena. Exhibitors will be asked to walk, extend the walk, jog, extend the jog, lope, extend the lope, stop from any gait, back, side pass to and from the rail, and turn of 180 degrees or greater. Any class size greater than 8 may be worked in lots at show management or judge's discretion depending on arena capacity and safety. No cross entry to Ranch Rail Open, Jr/Sr Ex W/J same horse/rider combination.

RANCH CONFORMATION The purpose of ranch conformation is to present a well-mannered horse which reflects a positive combination of balance, structural correctness, and movement with appropriate breed and sex characteristics and adequate muscling. The ideal Ranch conformation horse should have a natural ranch horse appearance from head to tail. Horses are to be shown in a good working halter: rope, braided, nylon or plain leather. Horses may be shown in a leather lead shank with an attached chain either under or over the nose. Banding, braiding, hoof polish, tail extensions and trimming of ears are discouraged but will not be penalized.

RANCH RIDING, LIMIT RIDER W/J The purpose of Ranch Riding horse should reflect the versatility, attitude, and movement of a working horse. The horse's performance should simulate a horse riding outside the confines of an arena and that of a working ranch horse. This class should show the horse's ability to work at a forward and working speed while under control by the rider. Light contact should be rewarded, and horse shall not be shown on a full drape of reins. Allow posting and holding the saddle horn. The horses head position should be elevated and above the level at all gaits. The overall manners and responsiveness of the horse while performing the maneuver requirements, and the horse's quality of movement are the primary considerations. Exhibitors will be asked to walk, extend the walk, jog, extend the jog, stop from any gait, back, and turn of 180 degrees. Cross entry is permitted into walk/jog and 3 gait classes.

RANCH RIDING OPEN The purpose of Ranch Riding horse should reflect the versatility, attitude, and movement of a working horse. The horse's performance should simulate a horse-riding outside the confines of an arena and that of a working ranch horse. This class should show the horse's ability to work at a forward and working speed while under control by the rider. Light contact should be rewarded and horse shall not be shown on a full drape of reins. Allow posting and holding the saddle horn. The horses head position should be elevated and above the level at all gaits. The overall manners and responsiveness of the horse while performing the maneuver requirements, and the horse's quality of movement are the primary considerations.

a. Each horse will work individually, performing both required and optional maneuvers, and scored on the basis of 0 - 100, with 70 denoting an average performance.

b. Each maneuver will receive a score that should be added or subtracted from 70 and is subject to a penalty that should be subtracted.

c. Each maneuver will be scored on the following basis, ranging from plus 1 ½ to minus 1 1/2 :

- i. -1 ½ extremely poor
- ii. -1 very poor
- iii. - ½ poor
- iv. 0 Correct
- v. + ½ good
- vi. + 1 very good
- vii. + 1 ½ excellent.

d. Maneuver scores are to be determined and assessed independently of penalty points.

e. The required maneuvers will include the walk, trot and lope in both directions: and the extended trot and extended lope in at least one direction; as well as stops and back.

f. Three (3) optional maneuvers may include a side pass, turns of 360 degrees or more, changes of lead (simple or flying), walk, trot or lope over a pole(s); or some reasonable combination of maneuvers that it would be reasonable for a ranch horse to perform.

g. The maneuvers may be arranged in various combinations with the final approval of the judge.

h. The overall cadence and performance of the gaits should be with an emphasis on forward movement, free-flowing, and ground covering for all gaits. Transitions should be performed where designated with smoothness and responsiveness. i. There is no time limit.

j. One of the suggested patterns may be used; however a judge may utilize a different pattern as long as all required maneuvers and the three (3) or more optional maneuvers are included. Should a judge use one of his/her own patterns it is recommended to not have a stop following an extended lope.

k. The use of natural logs is encouraged.

l. Posting at the trot is acceptable.

m. Touching or holding the saddle horn is acceptable.

RANCH RIDING OPEN (continued)

n. Apparel and Equipment:

- i. No hoof polish**
- ii. No braided or banded manes or tail extensions.**
- iii. Trimming inside of ears is discouraged. **
- iv. Trimming bridle path is allowed, also trimming of fetlocks or excessive (long) facial hair.
- v. Silver on bridles and saddles is discouraged and will not count over a good working outfit.
- vi. It is suggested competitors use a breast collar and a rear cinch.
- vii. Attire should be conservative in nature and reflect what would be seen on a working ranch. Embellished western pleasure attire is not allowed. Chaps and chinks are allowed.

o. Penalties:

i. One (1) point penalty:

1. Too slow/per gait
2. Over bridled
3. Out of frame
4. Break of gait at walk or jog for 2 strides or less.

ii. Three (3) point penalties:

1. Break of gait at walk or jog for more than 2 strides
2. Break of gait at lope
3. Wrong lead or out of lead
4. Draped reins
5. Out of lead or cross-cantering more than two strides when changing leads.
6. Trotting more than three strides when making a simple lead change.
7. Severe disturbance of any obstacle.

iii. Five (5) point penalties:

1. Blatant disobedience (kick, bite, buck, rear, etc.) for each refusal.

iv. Placed below horses performing all maneuvers:

1. Eliminates maneuver
2. Incomplete maneuver

v. Zero (0) score:

1. Illegal equipment.
2. Willful abuse.
3. Major disobedience or schooling.

vi. No specific penalties will be incurred for nicks/hits on logs but deduction may be made in maneuver score.

vii. No specific penalties will be incurred for over/under spins but deduction may be made in maneuver score



I Have An APP For That!

Friday July 19th, 2024 Start time 8 am

- 1 ApHC Yearling In Hand Trail
- 2 Trail In Hand Open *+
- 3 Trail In Hand Jr Ex. 18 Yrs. & Under *+
- 4 Trail Horse In Hand, Adolescent Three Years & Under (Horse) *+
- 5 Miniature Horse Obstacle in Hand, 38" and under *+
- 6 Mariann Bonwell Walk Trot Trail English or Western 10 Yrs. & Under (ATSM/SEI helmets required!) *+
- 7 ApHC Non-Pro Walk-Trot Trail 19 & over
- 8 Trail Horse English or Western Limit Rider Walk-Trot *+
- 9 Trail Horse English or Western Green 1st and 2nd Year W/T *+
- 10 ApHC Trail 10 & Under Walk Trot
- 11 ApHC Trail 18 Yrs. & Under
- 12 Trail Horse English or Western, Junior Exhibitor 18 Yrs. & Under *+
- 13 ApHC Non-Pro Trail 19 Years & Over
- 14 Trail Horse English or Western, Senior Exhibitor 19 & over *+
- 15 ApHC Trail Horse All Ages
- 16 Trail Horse Jr Ex & Sr Ex, **Championship** Qual classes 12 & 14 *+
- 17 **Jackpot** Trail Horse English or Western (No points)
- 18 ApHC Non-Pro Ranch Trail Walk Trot 19 Years & Over
- 19 ApHC Ranch Trail 18 Years & Under
- 20 ApHC Non-Pro Ranch Trail 19 Years & Over
- 21 ApHC Ranch Trail All Ages
- 22 Ranch Horse Trail Walk Trot All Ages (No NEZ points) *
- 23 Ranch Horse Trail Open (No NEZ points) *
- 24 ApHC Reining 18 Years & Under
- 25 ApHC Reining Non-Pro 19 & over
- 26 Reining Open **NRHA Pattern #7** *+
- 27 **Jackpot** Reining (No points), **NRHA Pattern #1**
- 28 ApHC Ranch Reining 18 Years & Under
- 29 ApHC Non-Pro Ranch Reining 19 Years & Over
- 30 ApHC Ranch Reining All Ages
- 31 Ranch Reining Open All Ages, **VRH PATTERN #4** (No NEZ or WSH points)
- 32 ApHC Non-Pro Ranch Riding Walk Trot 19 Years & Over
- 33 ApHC Ranch Riding 18 Years & Under
- 34 ApHC Non-Pro Ranch Riding 19 Years & Over
- 35 ApHC Ranch Riding All Ages
- 36 Ranch Riding Open **AQHA Ranch Riding Pattern #4**
- 37 Ranch Riding Limit Rider, Walk Jog **WSH Ranch Riding Pattern #2 W/J**
- 38 ApHC Ranch Rail Pleasure 18 Years & Under
- 39 ApHC Non-Pro Ranch Rail Pleasure Walk Trot 19 Years & Over
- 40 ApHC Non-Pro Ranch Rail Pleasure 19 Years & Over
- 41 ApHC Ranch Rail Pleasure All Ages
- 42 Ranch Rail Open, Jr/Sr Ex Walk-Jog (No NEZ points) *
- 43 Ranch Rail Open *+
- 44 **Jackpot** Ranch Rail (No points)
- 45 ApHC Ranch Conformation 18 Years & Under
- 46 ApHC Ranch Non-Pro Conformation 19 Years & Over
- 47 ApHC Ranch Conformation
- 48 Ranch Conformation *+

Saturday July 20th, 2024

Start time -8am

- 49 ApHC Hunter In Hand Stallion
- 50 ApHC Non-Pro Hunter In-Hand Stallion
- 51 ApHC Hunter In Hand Geldings
- 52 ApHC Non-Pro Hunter In-Hand Geldings
- 53 ApHC Hunter In Hand Mares
- 54 ApHC Non-Pro Hunter In-Hand Mares
- 55 ApHC Junior Stallion
- 56 ApHC Senior Stallions
- 57 Champion ApHC Stallions
- 58 ApHC Non-Pro Stallions All Ages (Horse)
- 59 ApHC Junior Geldings
- 60 ApHC Senior Geldings
- 61 Champion ApHC Geldings
- 62 ApHC Non-Pro Geldings All Ages (Horse)
- 63 ApHC Youth Geldings 18 Years & Under
- 64 ApHC Junior Mares
- 65 ApHC Senior Mares
- 66 Champion ApHC Mares
- 67 ApHC Non-Pro Mares All Ages (Horse)
- 68 ApHC Youth Mares 18 Years & Under
- 69 ApHC FPD All Ages All Sex
- 70 ApHC Most Colorful
- 71 ApHC Non-Pro Most Colorful
- 72 ApHC Youth Most Colorful 18 & under
- 73 **Jackpot** Most Colorful (No points)
- 74 Miniature Horse Halter, 38" and Under, Any Age, Any Sex (registration required) *+
- 75 Quarter Horse Halter Any Age, Any Sex (registration required) *+
- 76 Appaloosa Horse Halter Any Age, Any Sex (registration required) *+
- 77 Arabian And Half Arabian Halter Horse Open (registration required) *+
- 78 All Other Breeds Stock Type (must declare breed with secretary) *+
- 79 All Other Breeds Non-Stock Type (must declare breed with secretary) *+
- 80 All Other Breeds Halter, Championship (must declare breed with secretary) *+ Qualifying classes 74-79
- 81 ApHC Showmanship 10 And Under Walk Trot
- 82 ApHC Western Showmanship 18 Years and Under
- 83 ApHC Non-Pro Western Showmanship 19 Years and Over
- 84 Showmanship In Hand English or Western Junior 13 Years & Under *+
- 85 Showmanship In Hand English or Western Junior 14-18 Years *+
- 86 Showmanship In Hand English and Western Senior Am 19 & over *+
- 87 Showmanship In Hand English and Western Limit Handler JR/SR AM *+
- 88 **Jackpot** Showmanship (no points)
- 89 ApHC Yearling Longe Line
- 90 ApHC Non-Pro Yearling Longe Line 19 & over
- 91 Longe Line 3 Years and Under *+
- 92 ApHC Leadline 6 And under
- 93 Leadline Equitation English or Western Riders 6 and Under (ATSM/SEI helmets required) *+
- 94 Walk /Woah Equitation English or Western Riders 8 Years and Under (ATSM/SEI helmets required) *+
- 95 Pleasure Driving Green Horse/Pony 1st/ 2nd Year *+
- 96 Miniature Horse Pleasure Driving 38" and Under (registration required) *+

- 97 ApHC Pleasure Driving All Ages
- 98 ApHC Non-Pro Pleasure Driving 19 Years and Over
- 99 Reinsmanship Open *+
- 100 Pleasure Driving Horse/Pony Open*+
- 101 Pleasure Driving, Horse/Pony Open Championship *+ Qual Class #100
- 102 ApHC Bareback Horsemanship 18 Years & Under
- 103 ApHC Non-Pro Bareback Horsemanship 19 Years & Over
- 104 Bareback Horsemanship, English or Western Jr/Sr Am Walk/Trot + (No WSH)
- 105 Bareback Horsemanship, English or Western Jr/Sr Am (No NEZ points) *
- 106 ApHC Heritage
- 107 ApHC Heritage 18 Years & Under
- 108 ApHC Hunter Under Saddle 18 Years & Under
- 109 ApHC Non-Pro Hunter Under Saddle 19 Years & Over
- 110 ApHC Non-Pro Hunter Under Saddle Walk Trot 19 Years & Over
- 111 ApHC Hunt Seat Equitation 10 Years & Under Walk Trot
- 112 ApHC Hunt Seat Equitation 18 Years & Under
- 113 ApHC Non-Pro Hunt Seat Equitation 19 Years & Over
- 114 ApHC Non-Pro Walk Trot Hunt Seat Equitation 19 Years & Over
- 115 ApHC Saddle Seat Pleasure
- 116 ApHC Non-Pro Saddle Seat Equitation 19 Years & Over
- 117 ApHC Non-Pro Saddle Seat Pleasure 19 Years & Over
- 118 ApHC Hunter Under Saddle All Ages
- 119 Hunter Seat Equitation (Not to Jump) Jr. Ex. 18 yrs. & under *+
- 120 Hunter Seat Equitation (Not to Jump) Sr. Am. 19 yrs. & over *+
- 121 Huntseat Equitation (Not to Jump) Jr Ex & Sr Am Ex, Championship *+ Qual classes 119 & 120
- 122 English Pleasure, Green Horse 1st / 2nd Yr., W/T *+
- 123 Arabian & Half Arabian English Pleasure Open (registration required) *+
- 124 Quarter Horse Hunter Under Saddle (registration required) *+
- 125 All Other Breeds English Pleasure (must declare breed with secretary) *+
- 126 English Pleasure Horse Junior Exhibitor 18 & under *+
- 127 English Pleasure Horse Senior Exhibitor 19 & over *+
- 128 English Pleasure Limit Horse Walk Trot *+
- 129 English Pleasure Junior Horse 5 Years & under *+
- 130 English Pleasure Senior Horse 6 Years & over *+
- 131 English Pleasure Limit Horse *+
- 132 Advanced English Pleasure *+
- 133 English Pleasure Colored Horses *+
- 134 English Pleasure Non-Colored Horses *+
- 135 English Pleasure, Green Horse 1st & 2nd Yr. W/T/C *+
- 136 English Pleasure Open *+
- 137 **Jackpot** English Pleasure Horse Open (No points)
- 138 ApHC Nez Perce Stake Race
- 139 ApHC Nez Perce Stake Race 10 Years & Under Walk Trot
- 140 ApHC Nez Perce Stake Race 18 Yrs. & Under
- 141 ApHC Non-Pro Nez Perce Stake Race 19 Years & Older
- 142 ApHC Non-Pro Nez Perce Stake Race 19 Years & Over Walk Trot
- 143 Nez Perce Stake Race (Pole bending) Open (No WSH/NEZ points)
- 144 ApHC Figure 8 Stake Race
- 145 ApHC Figure 8 Stake Race 10 Years & Under Walk Trot
- 146 ApHC Figure 8 Stake Race 18 Years & Under

- 147 ApHC Non-Pro Figure 8 Stake Race 19 Yrs. & Over
- 148 ApHC Non-Pro Figure 8 Stake Race 19 Yrs. & Over Walk Trot
- 149 Figure 8 Stake Race Open (No WSH/NEZ points)
- 150 ApHC Camas Prairie Stump Race
- 151 ApHC Camas Prairie Stump Race 10 Years & Under Walk Trot
- 152 ApHC Camas Prairie Stump Race 18 Years & Under
- 153 ApHC Non-Pro Camas Prairie Stump Race 19 Years & Over
- 154 ApHC Non-Pro Camas Prairie Stump Race 19 Years & Over Walk Trot
- 155 Open Barrels (No WSH/NEZ points)
- 156 ApHC Keyhole Race
- 157 ApHC Keyhole Race 10 Years and Under Walk Trot
- 158 ApHC Keyhole Race 18 Years and Under
- 159 ApHC Non-Pro Keyhole Race 19 Years and Over
- 160 ApHC Non-Pro Keyhole Race 19 Years and Over Walk Trot
- 161 Keyhole Race Open (No WSH/NEZ points)

Sunday July 21st, 2024 – 8am

- 162 ApHC Western Horsemanship 10 Years & Under Walk Trot
- 163 ApHC Western Horsemanship 18 Yrs. & Under
- 164 ApHC Western Horsemanship Non-Pro 19 Years & Over
- 165 ApHC Western Horsemanship Non-Pro 19 Years & Over Walk Trot
- 166 ApHC Western Pleasure 18 Years & Under
- 167 ApHC Non-Pro Western Pleasure 19 Years & Over
- 168 ApHC Non-Pro Western Pleasure Walk Trot 19 Years & Over
- 169 ApHC Western Pleasure All Ages
- 170 Western Pleasure Limit Horse W/J/L *+
- 170a Equitation, Walk Trot, E/W, Riders 10 & Under *+
- 171 Western Seat Equitation Limit Rider Jr. & Sr. Am. W/J *+
- 172 Western Seat Equitation Jr. Ex. 18 Years & under *+
- 173 Western Seat Equitation Sr. Am. 19 Years & over *+
- 174 Western Pleasure Colored Horses *+
- 175 Western Pleasure Non-Colored Horses *+
- 176 Western Pleasure Green Horse 1st & 2nd Year W/J *+
- 177 Western Pleasure Green Horse 1st & 2nd Year W/J/L *+
- 177a Walk Trot E/W Pleasure, Riders 10 & Under *+
- 178 Western Pleasure Horse Jr Ex. 18 Yrs. & under *+
- 179 Western Pleasure Horse Sr. Ex. 19 Yrs. & over *+
- 180 Western Pleasure Jr Horse 5 Yrs. & under *+
- 181 Western Pleasure Sr Horse 6 Yrs. & over *+
- 182 Arabian And Half-Arabian Western Pleasure Open (registration required) *+
- 183 Quarter Horse Western Pleasure Open (registration required) *+
- 184 All Other Breed Western Pleasure (registration required) *+
- 185 Western Pleasure Horse Open
- 186 Advanced Western Pleasure Horse *+
- 187 **Jackpot** Western Pleasure Horse Open (No points)

Fistful Of Silver 2024 Entry Forms

ONLY ONE HORSE/OWNER PER ENTRY FORM – PLEASE PRINT OR TYPE – CIRCLE CLASS NUMBERS

NAME OF HORSE OWNER: _____
 ApHC NUMBER: _____ ApHC Non-Pro _____ OHA NUMBER: _____
 WSH Member Number _____ USEF/WSH/Breed AM Number _____
 ADDRESS: _____
 CITY: _____ STATE: _____ ZIP: _____
 EMAIL: _____ PHONE: _____

WSH Permanent

Show Assigned

NAME OF HORSE: _____
 BREED _____ REGISTRATION #: _____
 YEAR FOALD: _____ SEX: (circle) S M G

2nd Registry same horse:
 Name if different from above _____
 BREED _____ REGISTRATION #: _____

3rd Registry same horse:
 Name if different from above _____
 BREED _____ REGISTRATION #: _____

EXHIBITOR: _____
 ApHC NUMBER: _____ ApHC Non-Pro _____ OHA NUMBER: _____
 WSH Member Number _____ USEF/WSH/Breed AM Number _____
 ADDRESS: _____
 CITY: _____ STATE: _____
 ZIP: _____ PHONE: _____

YOUTH/NON-PRO BIRTHDATE: _____
 RELATIONSHIP OF OWNER TO YOUTH/NON-PRO: _____

Please Stable with _____
 Arrive _____ Depart _____

PLEASE FILL IN THE NUMBERS OF CLASSES YOU ARE ENTERING PRE-ENTER 4 CLASSES AND POST ENTER AT SHOW FOR REGULAR FEE

PLEASE REMEMBER TO INCLUDE PHOTOCOPIES OF THE FOLLOWING THAT APPLY:

- ~Registration Papers ~2024 ApHC Membership Card ~2024 WSH Membership Cards ~2024 Amateur/Non-Pro Cards**
- ~2024 ApHC /USEF/WSH Amateur Card /Breed Non-Pro Card**

Show Fees:

ApHC Open Class(es)x/\$24=\$

ApHC Youth Class(es) x\$18=\$

ApHC Non-Pro Class(es)x\$22=\$

WSH/NEZ Class(es)x\$20= \$

All Non-Sanctioned Class(es)x \$20=\$

WSH Non-Member Fee x \$3 Per Exhibitor/Judge (\$6 for dual Judge) =\$

Post Entry One Time Flat Fee x \$10=

Most Colorful Halter Jackpot \$50

Showmanship Jackpot x\$50=

Trail Horse Jackpot x\$50=

Ranch Rail Jackpot x\$50=

Reining Jackpot x\$50=

Western Pleasure Jackpot x \$50=\$

English Pleasure Jackpot x \$50=\$

One Day Stalls x \$55=\$

Two Day Stalls x \$85=\$

Three Day Stall x \$115= \$

One Day Tack Stalls x\$25=\$

Weekend Tack Stalls x\$50=\$

All Camping x\$45 /day=\$

Haul in fee (non-stalled) x\$15=

Office Fee (One time fee) \$5=

TOTAL ENCLOSED \$

Checks payable: P.E.A.C Check # CK Amt:

Open Check # Amt Due:

Post Enter at Regular Fee? Yes or No

SHOW FEES

AOB points go to: For Class #'s:

My Zone is:

Please send all Entry and Release forms and copies of Membership and Horse Registration papers to:

PEAC Fistful of Silver
Dennis Weitman
24201 E. Joseph Ave.
Otis Orchards, WA 990247
509-995-9867

peacoffice2@gmail.com



Release Forms:

Please Read Before signing both forms!

RELEASE, WAIVER, HOLD HARMLESS, ASSUMPTION OF RISK, DEFEND AND INDEMNIFY AGREEMENT FOR INFECTIOUS DISEASES INCLUDING COVID-19 RELATED LOSS WARNING:

IMPORTANT NOTICE BY SIGNING THIS AGREEMENT, YOU ARE GIVING UP CERTAIN LEGAL RIGHTS, INCLUDING THE RIGHT TO RECOVER DAMAGES IN CASE OF ILLNESS, INJURY, OR DEATH (collectively "Loss") ARISING OUT OF YOUR PRESENCE AT THE FACILITY SPECIFICALLY RELATED TO COVID-19 OR ANY OF ITS MUTATIONS, FORMS, DERIVATIVES, OR OTHER INFECTIOUS DISEASES (collectively "COVID-19").

I, the undersigned, hereby enter into this Release, Waiver, Hold Harmless, Assumption of Risk, Defend, and Indemnify Agreement for Infectious Diseases Including COVID-19 Related Loss ("Agreement") in consideration of my, and my minor child if applicable (collectively "I", "me", or "my"), ability and permission to access, utilize, occupy, visit, attend, or otherwise be present at or participate in a Washington State Horsemen/Northeast Zone/Palouse Empire Appaloosa Club ("WSH/NEZ/PEAC") sponsored, hosted, organized or in any other manner WSH/NES/PEAC affiliated, event or activity (collectively "Fistful of Silver") during and after the COVID-19 pandemic, for any reason, whether or not related to equines or equine activities.

1. Risk of Loss/Protective Measures/No Guarantee: By signing this Agreement, I hereby acknowledge that I have familiarized myself with the risk of Loss being present at the Event for any reason whatsoever and the protective measures at the Event intended to minimize my risk of exposure to COVID-19. I agree the protective measures are satisfactory and sufficient for me to accept and assume the risk of my COVID-19 exposure resulting from accessing, utilizing, occupying, visiting, attending, or otherwise being at the Event attended by other individuals; however, I understand and agree that Released Parties cannot guarantee: (a) the protective measures can or will prevent my exposure to COVID-19; (b) will be complied with by all individuals at the Event; or (c) that others will not act in a negligent manner that may contribute to my Loss or contraction of COVID-19. I agree to fully comply with all protective measures required by PEAC or the Event as they now exist or may be revised from time-to-time. I accept full responsibility for my own safety and the sanitization of myself and my personal property and/or other personal property I contact at the Event. If I am a parent or legal guardian of a minor individual at the Event, I consent to the minor's presence at the Event and agree to remain responsible for the minor's Loss and minor's compliance with all required protective measures.

2. Medical Attention/Disclosure: I understand and agree that engaging in equine activities or merely being at the Event exposes me to inherent risks of personal injury that may require medical attention including, but not limited to, first aid and/or emergency medical care. I therefore consent to personal contact by Released Parties and/or medical personnel deemed necessary for providing for my care at the Event and/or the hospital, even at the risk of my COVID-19 exposure. I agree to hold Released Parties harmless for such medical attention and any Loss directly or indirectly resulting therefrom. I agree that in the event I am diagnosed as infected with COVID-19, I authorize medical personnel to provide the WSH/NEZ/PEAC information regarding my Loss and treatment for contact tracing or any other purpose.

3. Release/Hold Harmless/Defend/Indemnify: I agree to release, hold harmless, defend, and indemnify Palouse Empire Appaloosa Club, and its related entities, agents, successors, assigns, instructors, trainers, employees, volunteers, independent contractors, working students, assistants, sponsors, guests, visitors, members, managers, officers, directors, owners, and each of their respective heirs, beneficiaries, relatives, and any others acting on their behalf (collectively "Released Parties") from and against any liability, attorneys' fees, costs, or other Loss I may incur arising out of or in any way connected with my exposure to or contraction of COVID-19 as a direct or indirect result of my presence at the Event whether by my negligence or the negligence or other wrong doing of Released Parties (except gross negligence, or reckless or willful and wanton conduct).

4. Bound Parties/Governing Law/Jury/No Expiration/Time Limitations/Severability/Modification: I understand and agree the terms of this Agreement are binding on my spouse, partner, family members, minor child, heirs, agents, trustees, beneficiaries, representatives, relatives, successors, and assigns and I agree to all the terms and conditions of this Agreement on my own behalf and on behalf of my minor for purposes of permitting our presence at the Event. In the event of a claim or dispute arising out of or relating to the interpretation or enforcement of this Agreement, I agree Washington law applies, that all disputes surviving this Agreement must be resolved exclusively by the state court in Pierce County, Washington, and I waive my right to a jury trial. I agree that this Agreement does not expire and that any surviving claims must be brought within one (1) year of the date accrued. If any provision of this Agreement is deemed invalid or unenforceable, the remaining provisions shall be fully valid and enforceable of the law. This Agreement can only be modified in writing signed by myself and the WSH/NEZ President.

WARNING BEFORE SIGNING THIS FORM, I ACKNOWLEDGE THAT I HAVE READ AND FULLY UNDERSTAND ALL OF THE INFORMATION CONTAINED THEREIN. I ACKNOWLEDGE THAT I DO NOT NEED ANY FURTHER EXPLANATION OF ITS CONTENTS AND WAIVE ANY FURTHER EXPLANATION. I HAVE VOLUNTARILY AGREED TO ITS TERMS AND PROVISIONS, UNDERSTAND AND AGREE THAT I HAVE OTHER FACILITIES TO CHOSE FROM, AND AGREE THAT NO OTHER STATEMENT, REPRESENTATIONS, OR INDUCEMENT, APART FROM WHAT IS STATED IN THIS AGREEMENT, HAVE BEEN MADE TO ME TO OBTAIN MY CONSENT AND MY SIGNATURE.

Date: _____ Participants Signature (my own behalf and for minor): _____

Print Name: _____

Phone Number _____ Email: _____

Minor Participants Name & Birth Date: _____

RELEASE, WAIVER, HOLD HARMLESS, DEFEND AND INDEMNIFICATION AGREEMENT THIS DOCUMENT AFFECTS YOUR LEGAL RIGHTS PLEASE READ CAREFULLY BEFORE SIGNING

The undersigned, as a Participant/Spectator/Visitor/Horse Owner/Contractor/Volunteer (collectively "Participant"), on his/her own behalf and, if applicable, as the Parent/Legal Guardian of a minor Participant, for good and valuable consideration, agrees to the terms and conditions of this Release, Waiver, Hold Harmless, Defend, and Indemnification Agreement ("Release"). Assumption of Risk and Waiver: Participant understands and accepts the risks of engaging in Equine Activities, while mounted or unmounted, as well as merely being near a horse, pony, mule, donkey, or hinny (collectively "equine"), include, but are in no way limited to, faulty equipment or tack that cause injury or death, Released Parties' failure to make a reasonable effort to determine the ability of Participant to engage safely in an equine activity or to safely manage the particular equine provided based on Participant's representations of his or her ability, Released Parties' failure to conspicuously post warning signs of a dangerous inconspicuous condition on the real property, as well as: (1) the propensity of an equine to behave in a way that may result in injury or death to a person on or near it (ex.: jump, run, kick, buck, bolt, spin, rear up, strike, bite, stumble, fall, etc.); (2) the unpredictability of an equine's reaction to a sound (ex.: doors opening and closing, snow and ice falling, rain, wind, thunder, voices, music, guns, planes, cars, trucks, etc.), movement, or unfamiliar object (ex.: machinery, equipment, obstacles, buggies, carts, barrels, ground poles, cones, flowers, flags, golf carts, mini-bikes, whips, bats, construction material, etc.), person or animal (ex.: leashed or unleashed dogs, ducks, wildlife, equines, etc.); (3) a collision with an object or another animal (ex.: mounted equine, loose equine, etc.); (4) the potential for a person participating in an equine activity to act in a negligent manner, to fail to control the equine or to not act within his or her ability; and (5) natural hazards, including surface and subsurface conditions (ex.: ground holes, uneven terrain, slippery or deep footing, etc.). Participant agrees that engaging in Equine Activities under this Release includes, but is in no way limited to, those defined in the Washington Equine Activity Liability Statute, WA ST 4.24.530 et seq., as well as riding another's equine, petting, guiding, leading, mounting, feeding, watching, and otherwise interacting with or merely being in the vicinity of equines (collectively "Equine Activities"). Participant understands the injuries, death, loss, and damage that may result from the inherent risks of engaging in Equine Activities or just being near equines, that equines are powerful and have the potential to be dangerous, even without warning, and that the risks listed in this Release is just a sampling and Participant is not relying on Released Parties (defined below) to list all possible equine related risks. Participant understands that Washington State Horseman Horse Show Division ("WSH HSD") requires the wearing of an ASTM/SEI-certified equestrian helmet ("Helmet") consistent with the Washington State Horsemen rules. Participant understands and agrees that failing to wear a Helmet while engaged in Equine Activities increases the risk of serious injury and/or death, Participant is not relying on Released Parties to provide a Helmet, check a Helmet or its harness strap for proper fitting, or monitor the wearing of a Helmet at any time now or in the future. Participant understands and agrees that Participant has other riding associations and facilities to choose from, he/she has inspected the facility for the Equine Activities and is satisfied that all are reasonable and safe for Participant's intended use, he/she is voluntarily engaging in Equine Activities, he/she is directly and intentionally engaging in and assuming the risks of Equine Activities, and he/she agrees to at all times to be responsible for his/her personal safety. Participant agrees to purchase and maintain his/ her health and liability insurance, remain responsible for his/her medical expenses, and waives his/her right to any claims arising from his/her participation in or observation of any Equine Activities, being near equines, or merely being present on real property owned, leased, rented, borrowed, visited, or otherwise occupied or utilized by Released Parties. "Released Parties" herein includes the Washington State Horseman Horse Show Division, its members, officers, directors, employees, contractors, and their respective family members, heirs, agents, trustees, beneficiaries, employees, working students, volunteers, independent contractors, clinicians, guests, visitors, invitees, partners, members, managers, officers, directors, owners, lessors, lessees, licensors, licensees, and others acting on their behalf. Release, Hold Harmless, Defend, Indemnify: Participant agrees to release, hold harmless, defend, and indemnify Released Parties for any illness, injury, death, damage, or other loss (collectively "Loss") incurred by Participant or to Participant's property and/or equine, even if such Loss is caused in whole or in part by negligence or other fault of Participant or Released Parties (except gross negligence, or reckless or willful and wanton conduct). This Release shall not expire and shall remain in full force and effect in perpetuity.

Governing Law, Jurisdiction, Time/Liability Limitation, Attorneys' Fees, Jury Waiver: This Release shall be construed and enforced in accordance with the laws of the State of Washing-ton. All disputes relating to the interpretation and enforcement of this Release shall be resolved by the state court in Pierce County, Washington. Participant agrees that any and all claims for Loss by Participant against Released Parties must be brought within one (1) year of the date accrued and any surviving claim for personal property Loss is limited to two hundred and fifty dollars (\$250).

Participant agrees to reimburse Released Parties for any and all attorneys' fees and costs incurred by Released Parties in enforcing the terms of this Release and/or in defending or prosecuting any claims or causes of action involving or relating to Participant. Participant agrees to waive trial by jury in any action with Released Parties. Severability, Modification: If any provision of this Release is deemed invalid or unenforceable, the remaining provisions shall be valid and enforceable to the fullest extent of the law. The Release can only be modified if signed by Participant and WSH HSD Director. Certification: Participant certifies he/she read this Release and understands that signing this Release is required for Participant to participate in Equine Activities with Released Parties, knows that he/she has other instructors, facilities and/or horses to choose from, and voluntarily intends on his/her own behalf, and on behalf of minor Participant, and Participant's spouse, parents, family members, heirs, agents, trustees, beneficiaries, representatives, successors, and assigns, to be bound by the terms and conditions contained herein.

Date: _____ Participants Signature (my own behalf and for minor): _____

Print Name: _____ Phone Number/Email: _____

Address: _____

Emergency Contact & Phone Number: _____

Minor Participants Name & Birth Date: _____

Class #31 - Ranch Reining Open All Ages, VRH PATTERN #4

VRH AND NRSHA RANCH REINING

VRH PATTERN #4

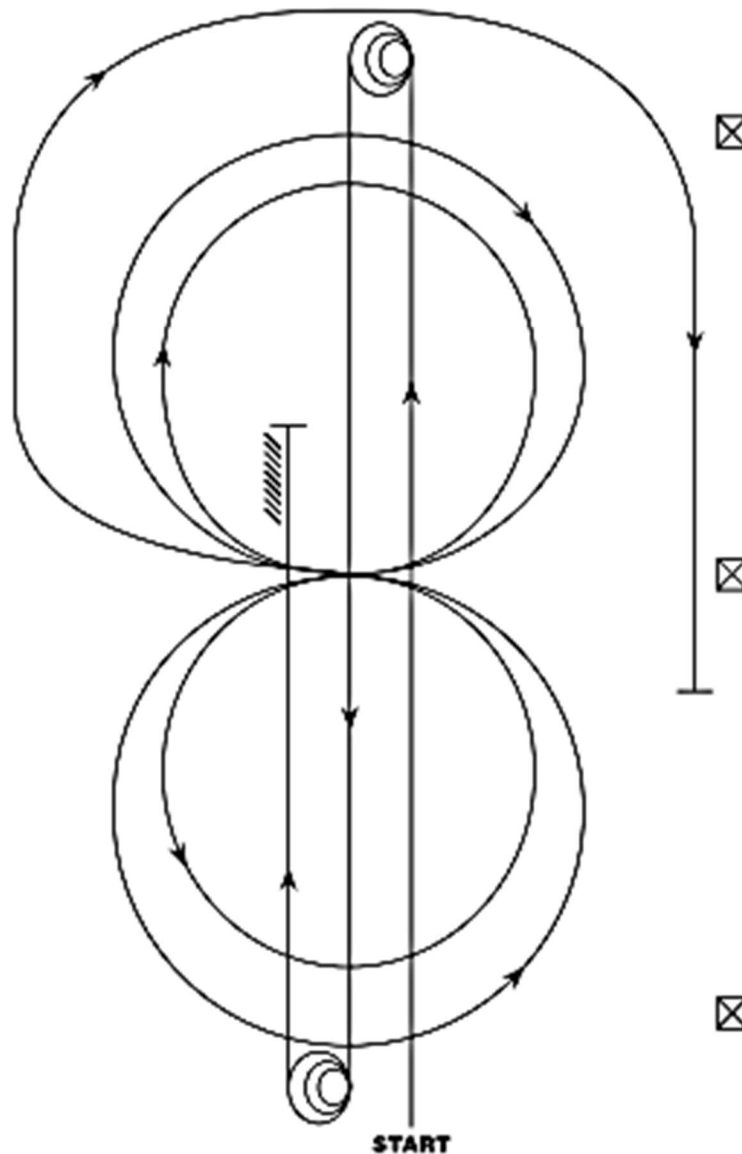

1. Run up center of arena past the end marker and do a sliding stop.
2. Complete 3 1/2 spins to the left.
3. Run down to opposite end of arena, past the end marker and do a sliding stop.
4. Complete 3 1/2 spins to the right.
5. Run past the center marker and do a sliding stop. Back at least 10 feet. Complete 1/4 turn to the left; hesitate.
6. Beginning on right lead, complete two circles to the right - the first one small and slow, the second one large and fast. Change leads at center of arena.
7. Complete two circles to the left - the first one small and slow, the second one large and fast. Change leads at center of arena.
8. Begin a large circle to the right but do not close this circle. Run down the right side of the arena, past the center marker and do a sliding stop at least 20 feet from the fence. Hesitate to show completion of pattern.

Class #26 - Reining Open NRHA Pattern #7

Pattern 7

1. Run at speed to the far end of the arena past the end marker and do a left rollback—no hesitation.
2. Run to the opposite end of the arena past the end marker and do a right rollback—no hesitation.
3. Run past the center marker and do a sliding stop. Back up to the center of the arena or at least ten feet (three meters). Hesitate.
4. Complete four spins to the right. Hesitate.
5. Complete four and one-quarter spins to the left so that horse is facing left wall or fence. Hesitate.
6. Beginning on the right lead, complete three circles to the right: the first two circles large fast; the third circle small and slow. Change leads at the center of the arena.
7. Complete three circles to the left: the first two circles large fast; the third circle small and slow. Change leads at the center of the arena.
8. Begin a large circle to the right but do not close this circle. Run straight down the right side of the arena past the center marker and do a sliding stop at least twenty feet (six meters) from the wall or fence. Hesitate to demonstrate completion of the pattern.

Pattern 7

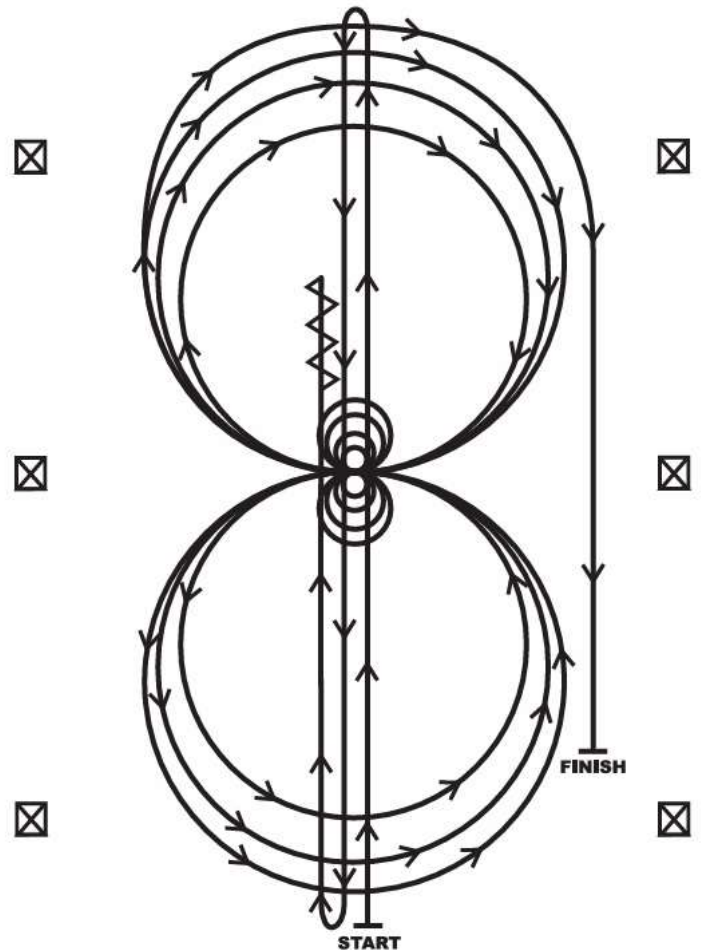

Class #27 -Jackpot Reining No points NRHA Pattern #1

Pattern 1

1. Run at speed to the far end of the arena past the end marker and do a left rollback—no hesitation.
2. Run to the opposite end of the arena past the end marker and do a right rollback—no hesitation.
3. Run past the center marker and do a sliding stop. Back up to center of the arena or at least ten feet (three meters). Hesitate.
4. Complete four spins to the right. Hesitate.
5. Complete four and one-quarter spins to the left so that horse is facing left wall or fence. Hesitate.
6. Beginning on the left lead, complete three circles to the left: the first circle large and fast; the second circle small and slow; the third circle large and fast. Change leads at the center of the arena.
7. Complete three circles to the right: the first circle large and fast; the second circle small and slow; the third circle large and fast. Change leads at the center of the arena.
8. Begin a large circle to the left but do not close this circle. Run straight up the right side of the arena past the center marker and do a sliding stop at least twenty feet (six meters) from wall or fence. Hesitate to demonstrate the completion of the pattern.

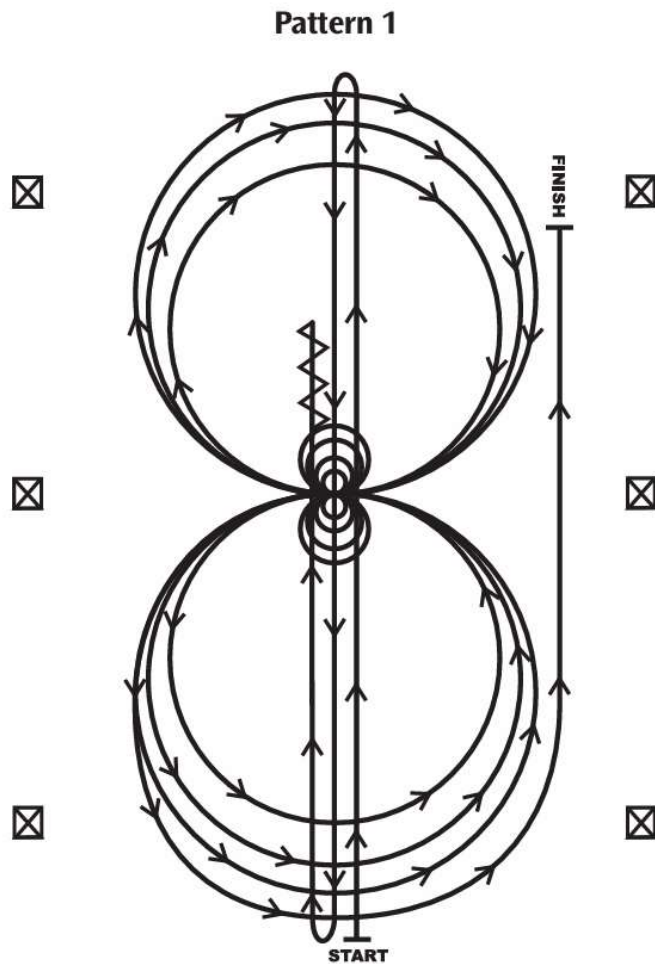

RANCH RIDING - PATTERN 4

LEGEND	
.....	Walk
... ..	Extended Walk
- - -	Trot
- - - -	Extended Trot
————	Lope
————	Extended Lope
//////	Back
//	Load Change

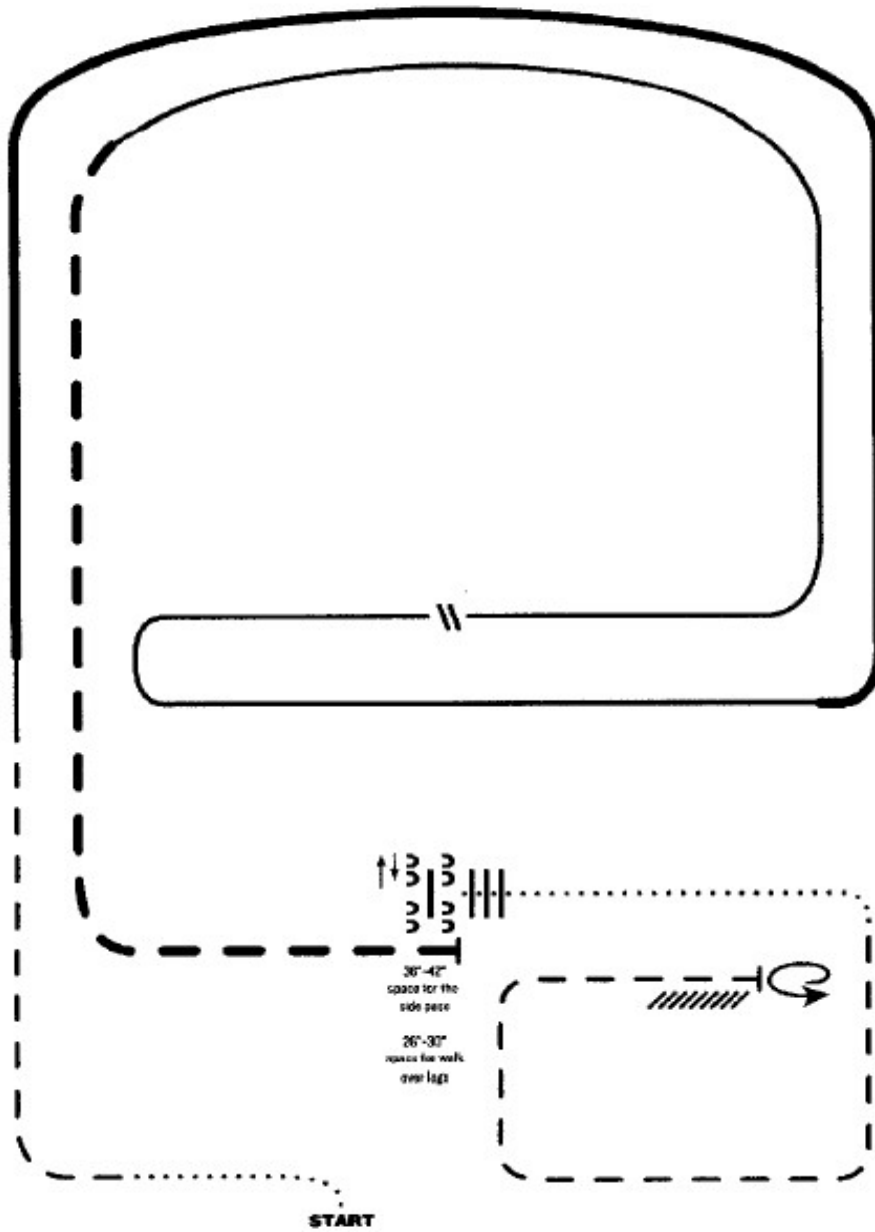

1. Walk
2. Trot
3. Extended lope right lead
4. Lope right lead
5. Change leads (simple or flying)
6. Lope left lead
7. Extended trot
8. Stop, side pass left, side pass right, 1/2 way
9. Walk over logs
10. Walk
11. Trot square
12. Stop, 360° turn left, and back

© 2001 American Quarter Horse Association
 All rights reserved. No part of this publication may be reproduced without the prior written permission of the American Quarter Horse Association.

37 Ranch Riding Limit Rider, Walk Jog * WSH Ranch Riding Pattern #2 W/J

RANCH RIDING - PATTERN 2 WALK/JOG

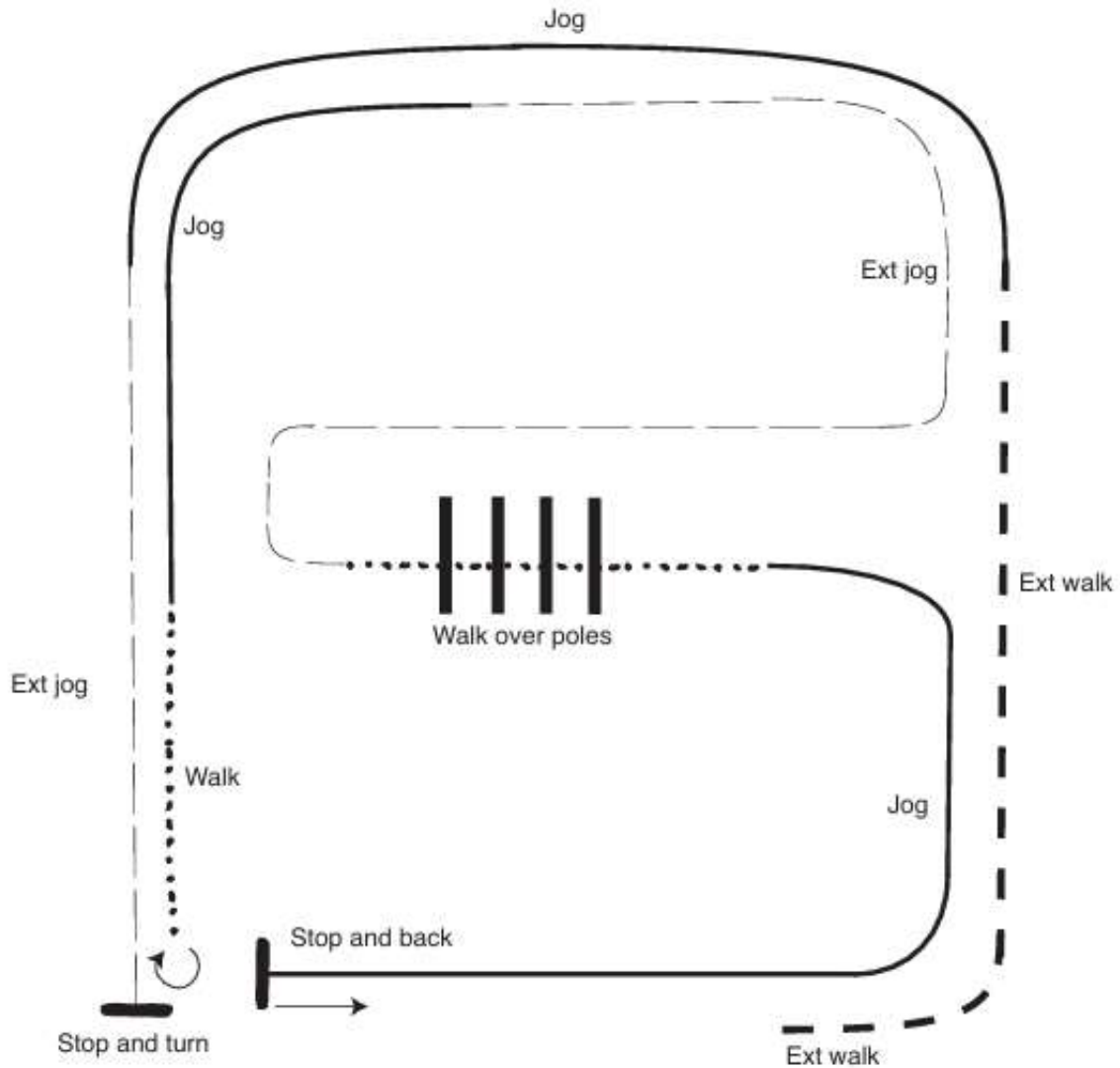

- Walk
 - Extended Walk
 - Jog
 - - - Extended Jog
 - Back
 - ↻ Turn
- 26" - 30" spacing between poles/logs

1. Extended walk corner and line
2. Jog
3. Extended jog line
4. Stop and 180 degree turn either direction
5. Walk 1/2 the line
6. Jog 1/2 the line and corner
7. Extend jog around corners
8. Walk over poles
9. Jog corners
10. Stop and back